

# The Harman Kardon Model CD201

Manual No. 43A

## ULTRAWIDEBAND LINEAR PHASE CASSETTE DECK

# Technical Manual



**harman/kardon**

240 CROSSWAYS PARK WEST, WOODBURY, N.Y. 11797  
PRINTED IN JAPAN 1112-H15243A7 P-08823

CD201

**CONTENTS**

SPECIFICATIONS ..... 2  
 COMPONENTS AND THEIR FUNCTIONS ..... 2, 3  
 SELECTION OF POWER SUPPLY VOLTAGE .... 3  
 INTERNAL VIEW ..... 4  
 DISASSEMBLY PROCEDURES ..... 4-6  
 ALIGNMENT PROCEDURES ..... 7-11  
 MECHANISM ADJUSTMENT  
 AND CONFIRMATION ..... 12,13  
 BLOCK DIAGRAM ..... 14  
 CIRCUIT DESCRIPTION ..... 15

IC FUNCTIONAL BLOCK DIAGRAM ..... 15  
 TIMING CHART ..... 16,17  
 GENERAL UNIT EXPLODED VIEW ..... 18  
 GENERAL UNIT PARTS LIST ..... 19  
 CASSETTE MECHANISM EXPLODED VIEW .... 20  
 CASSETTE MECHANISM PARTS LIST ..... 21  
 ELECTRICAL PARTS LIST ..... 22-25  
 PACKAGE ..... 26  
 SCHEMATIC DIAGRAM ..... 27  
 WIRING DIAGRAM ..... 28

**SPECIFICATIONS**

Track Configuration 4-track 2 channel Stereo  
 Cassette Deck

• **MECHANICAL SECTION**

	Nominal	Limit
Tape Speed	4.75cm/sec.	±1.5%
Wow and Flutter	0.05% ≤ 0.08%	
F.F./REW Time	for C-60 Cassette 90 sec. ≤ 100 sec.	
Motor	DC Serve motor	
Take Up Torque	50 gr. cm	35 ~ 70 gr. cm
F.F Torque	100 gr. cm	70 ~ 150 gr. cm
REW Torque	100 gr. cm	70 ~ 150 gr. cm

• **HEAD SECTION**

Recording/Playback Fe-Al-Si Alloy Core  
 Erase Ferrite Core

• **AMPLIFIER SECTION**

Input Censitivity	MIC	0.38mV ≤ 0.5mV
	LINE	38mV 30 ~ 60mV
Input Impedance	MIC	2.7kΩ ±0.7kΩ
	LINE	14kΩ 10 ~ 20kΩ

Signal-to-Noise Ratio(DOLBY B to ON)	Nominal	Limit
at MIC input	52dB	≥ 48dB
	(Input 1kHz, 1.5mV for normal Tape)	
at LINE input	47dB	≥ 42dB
	(Input 1kHz, 100mV for normal Tape)	
Erase Ratio	65dB	≥ 60dB
	(Input 80Hz for metal tape)	
Channel Separation	50dB	≥ 35dB
	(Input 1 kHz)	
Crosstalk	75dB	≥ 60dB
	(Input 1 kHz)	

• **DIMENSIONS (WxHxD)** 17-3/7" x 4-1/3" x 12-4/7"  
 (443 x 110 x 320 mm)

• **WEIGHT** 17.6lbs. (8kg)

• **POWER SUPPLY** AC 110/120/220/240V,  
 50/60Hz

• **POWER CONSUMPTION** 30W

Specifications and components subject to change without notice.  
 Overall performance will be maintained or improved.

**COMPONENTS AND THEIR FUNCTIONS**

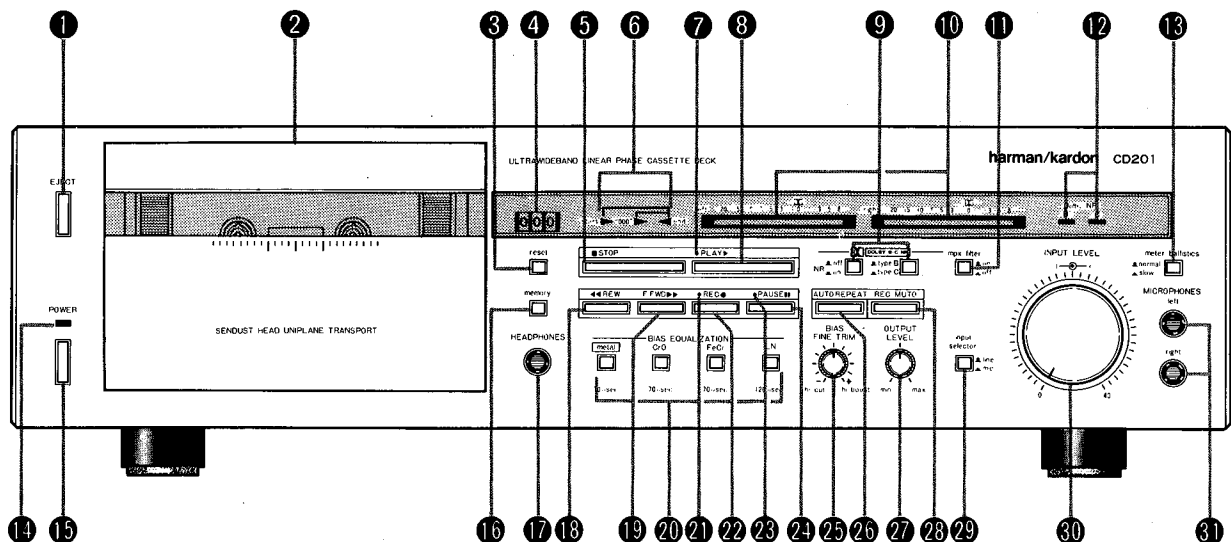

**1 EJECT BUTTON (EJECT)**  
 For opening the cassette compartment door.  
 The soft eject mechanism opens the door slowly when  
 this button is pressed.

**2 CASSETTE COMPARTMENT**

**3 RESET BUTTON (reset)**  
 For resetting the counter to "000".  
 Press this button to reset the TAPE COUNTER to "000"  
 when starting recording. This button is also used with  
 the MEMORY button to stop tape rewinding automati-  
 cally at the desired position.

**4 TAPE COUNTER**

For digital display of the position in a cassette tape. The figure changes as the tape runs. Cueing for the start of a melody is facilitated by making a note of the counter reading.

**5 STOP BUTTON (■ STOP)**

For stopping each operation. Pressing this button stops playback, recording, fast forwarding or rewinding of a tape. It also cancels standby state by PAUSE button operation.

**6 AUTOMATIC REPEAT RANGE INDICATOR**

For indication of the repeating range in a cassette tape by state by automatic repeat function.

**7 PLAY INDICATOR****8 PLAY BUTTON (PLAY▶)**

For playback of a tape. Press this button to start playback. The PLAY INDICATOR illuminates in green color.

**9 \*DOLBY NR SYSTEM SELECTOR (DOLBY B-C NR)****• NR ON/OFF Selector**

For recording or playback using the Dolby NR system. Press this switch to use the Dolby NR system. The green DOLBY NR INDICATOR (for B-type) or the yellow one (for C-type) illuminates according to the NR TYPE selector position. Press this switch again to invalidate the Dolby NR system.

**• NR TYPE Selector**

For selection of Dolby B- or C-type NR system. Depress this selector to select the Dolby C-type NR system. Press it again and the B-type is selected.

**10 LED LEVEL DISPLAY**

For clear indication of the recording or playback level.

**11 MPX FILTER SWITCH (mpx filter)**

For cutting the multiplex noise during recording of an FM stereo broadcasting program by using the Dolby B- or C-type NR system. Depress this switch to invalidate the MPX filter function.

**12 DOLBY NR INDICATORS (Dolby NR B, C)**

For indication of the validated Dolby NR system type.

**13 METER BALLISTICS SELECTOR (meter ballistics)**

For selection between normal and slow LED LEVEL DISPLAY recovery time.

**14 POWER INDICATOR****15 POWER SWITCH (POWER)**

For power turning on and off. When this switch is pressed with the AC cord plugged to an AC outlet, the POWER indicator illuminates.

**16 MEMORY BUTTON (memory)**

For automatic stopping of tape rewinding at a desired position in combination with the RESET button. Depress this button and push the RESET button during playback or recording to reset the TAPE COUNTER to "000".

When the tape is rewound in this state, tape running automatically stops at the position where the TAPE COUNTER indicates "000".

**17 HEADPHONES JACK (HEADPHONES)**

For connection of stereo headphones. The sound volume can be adjusted by the OUTPUT LEVEL control.

**18 REWIND BUTTON (◀◀REW)**

For rewinding of a tape at a high speed.

**19 FAST FORWARD BUTTON (F. FWD▶▶)**

For fast forwarding of a tape.

**20 TAPE SELECTORS (BIAS/EQUALIZATION)**

For selection of metal, CrO<sub>2</sub>, FeCr or LN position according to the type of the tape to be used.

**21 RECORD INDICATOR****22 RECORD BUTTON (REC●)**

For recording on a tape. Press this button and the PAUSE button at the same time to provide standby state for recording. The yellow PAUSE INDICATOR illuminates, and the red RECORD INDICATOR brinks. Recording starts when the PLAY button is pressed in this state.

**23 PAUSE INDICATOR****24 PAUSE BUTTON (PAUSE II)**

For temporary stopping of playback or recording. Also press this button with the RECORD button to provide standby state for recording.

**25 BIAS FINE TRIM KNOB (BIAS FINE TRIM)**

For setting of the optimal bias for the tape to be used. Normally set at the center position. Turn it counter-clockwise to attenuate the high signal level range, or clockwise to boost the high signal level range, during recording.

**26 AUTOMATIC REPEAT BUTTON (AUTO REPEAT)**

For automatic repeating of playback operation to enable endless playback.

When this button is pressed the AUTOMATIC REPEAT RANGE INDICATOR illuminates to indicate the playback range.

**27 OUTPUT LEVEL CONTROL (OUTPUT LEVEL)**

For control of the output level during playback or monitoring of the recording sound. It also control the volume of the sound monitored through headphones.

**28 RECORD MUTE BUTTON (REC MUTE)**

For providing a soundless interval during recording. To cut off undesirable sound between programs keep this button pressed until the next program starts. No sound is recorded as long as this button is kept pressed.

**29 INPUT SELECTOR (input selector)**

For selection of the input source for recording. LINE position: For recording from other components. MIC position: For recording from microphones.

**30 INPUT LEVEL CONTROL (INPUT LEVEL)**

For input level control during recording. The LED LEVEL DISPLAY shows the input level. The front side knob is for the left channel and the rear one is for the right channel. Both knobs are turned together by single-hand operation.

**31 MICROPHONE JACKS (MICROPHONES)**

For connection of recording microphones. Use low-impedance microphones.

\* Noise reduction system manufactured under license from Dolby Laboratories Licensing Corporation. "Dolby" and the double-D symbols are trademarks of Dolby Laboratories Licensing Corporation.

## SELECTION OF POWER SUPPLY VOLTAGE

To remove the cabinet bottom, refer to DISASSEMBLY PROCEDURES step [2] of page 4. Then turn the dial plate of voltage selector switch using a screwdriver to bring the correct voltage indication, 110V-120V-220V-240V, to the arrow mark.

## INTERNAL VIEW

### TOP VIEW

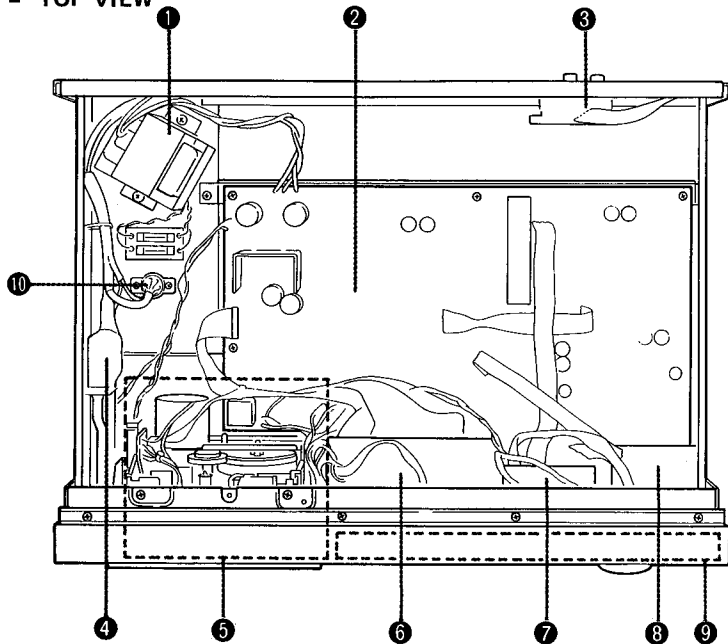

- ① POWER TRANSFORMER
- ② MAIN P.C. BOARD (PCB-1)
- ③ JACK P.C. BOARD (PCB-8)
- ④ POWER SWITCH
- ⑤ CASSETTE TAPE RECORDER MECHANICAL ASSEMBLY
- ⑥ LOGIC CONTROL P.C. BOARD (PCB-2)
- ⑦ DOLBY NR SWITCH P.C. BOARD (PCB-4)
- ⑧ METER AMP. P.C. BOARD (PCB-3)
- ⑨ PLATE ASSEMBLY
- ⑩ VOLTAGE SELECTOR

## DISASSEMBLY PROCEDURES

### 1 CABINET TOP REMOVAL

Remove the screws ① to ⑥ in Fig. 1 and then remove the cabinet top.

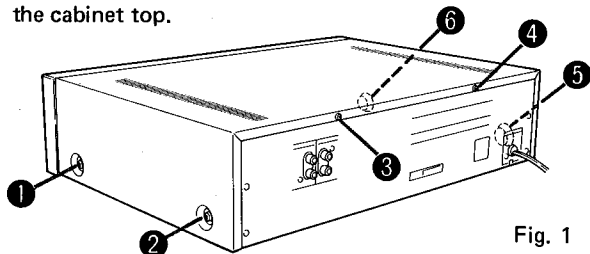

Fig. 1

### 2 CABINET BOTTOM REMOVAL

Remove the screws ① to ⑩ in Fig. 2 and then remove the cabinet bottom.

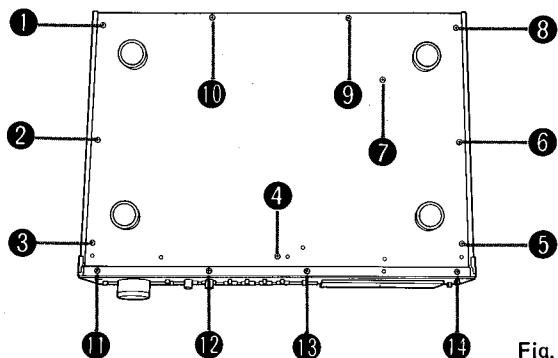

Fig. 2

### 3 FRONT PANEL ASSEMBLY REMOVAL

1. Remove the cabinet top. (Refer to step 1)
2. Unsolder the lead wires which are connected to rec., play and pause indicator P.C. board.
3. Pull out the input level knobs (Lch and Rch).
4. Remove the cassette door assembly.
5. Remove the screws ⑪ to ⑭ in Fig. 2 and ① to ④ in Fig. 3 and then remove the front panel assembly.

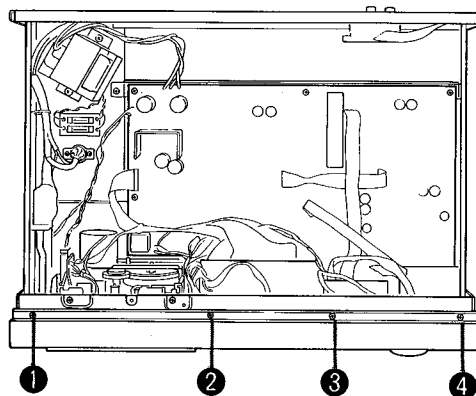

Fig. 3

### 4 METER AMP. P.C. BOARD REMOVAL

1. Remove the front panel assembly. (Refer to step 3)
2. Disconnect connector from LED level display assembly and remove the screws ① and ② in Fig. 4 and then remove the meter amp. P.C. board.  
\* Parts inspection and exchange would be possible at this condition.
3. When detaching the meter amp. P.C. board, unsolder the lead wires which are connected to the meter amp. P.C. board.

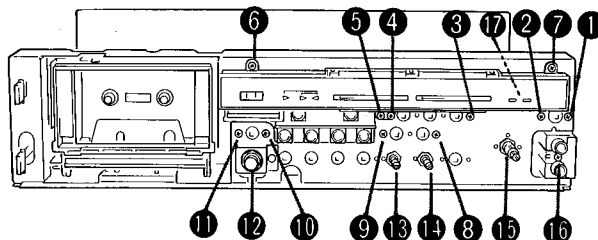

Fig. 4

**5 DOLBY NR SWITCH P.C. BOARD REMOVAL**

1. Remove the front panel assembly. (Refer to step 3 )
2. Remove the screw 17 in Fig. 4 (rear of plate assembly) and then remove dolby NR indicator P.C. board.
3. Remove the screws 3 and 4 in Fig. 4 and then remove the dolby NR switch P.C. board.

\* Parts inspection and exchange would be possible in this condition.

4. When detaching the dolby NR switch P.C. board, unsolder the lead wires which are connected to the dolby NR switch P.C. board.

**6 PLATE ASSEMBLY REMOVAL**

1. Remove the dolby NR switch P.C. board. (Refer to step 5 )
2. Pull out the connector which is connected to LED level display assembly.
3. Unsolder the lead wires which are connected to reed switch P.C. board.
4. Remove the belt of the counter.
5. Remove the screws 5 to 7 in Fig. 4 and then remove the plate assembly.

**7 LOGIC CONTROL P.C. BOARD REMOVAL**

1. Remove the plate assembly. (Refer to step 6 )
2. Pull out the push buttons of auto repeat and rec. mute.
3. Disconnect the connectors from main P.C. board and connector panel of cassette mechanical assembly.
4. Unsolder the lead wires which are connected to the logic control P.C. board.
5. Remove the screws 8 to 11 in Fig. 4 and then remove the logic control P.C. board.

**8 MAIN P.C. BOARD REMOVAL**

1. Remove the meter amp. P.C. board and logic control P.C. board. (Refer to step 4 and 7 )
2. Unsolder the lead wires which are connected to the main P.C. board.
3. Pull out the knobs of bias fine trim and output level.
4. Remove the hexagonal nuts 12 to 15 and the screw 16 in Fig. 4.
5. Remove the screws 1 to 4 in Fig. 5 and the screw 1 in Fig. 6 and then pull out main P.C. board backward.

**CAUTIONS ON REMOVAL OF SWITCH SHAFT (AUTO REPEAT AND REC MUTE) (REFER TO REF. NO. 207 OF PAGE 18)**

Whenever it is necessary to remove the shaft from the push switch for repairing purpose, be careful not to pull out the shaft with the push switch being locked (a state being pushed in). That may damage the lock mechanism of the push switch. Be sure to push the switch once more to release the lock, if the push switch is locked.

**9 CASSETTE TAPE RECORDER MECHANICAL ASSEMBLY REMOVAL**

1. Remove the main P.C. board. (Refer to step 8 )
2. Unsolder the lead wires and disconnect the connector which are connected to the cassette tape recorder mechanical assembly.

3. Remove the screws 5 and 6 in Fig. 5 and 1 and 2 in Fig. 7 and then remove the cassette tape recorder mechanical assembly backward.

\* When mounting, tighten screws 1 and 2 in Fig. 7 first and then 5 and 6 in Fig. 5.

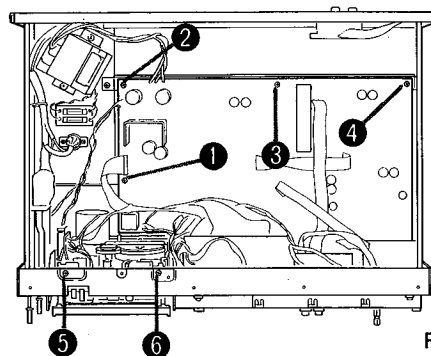

Fig. 5

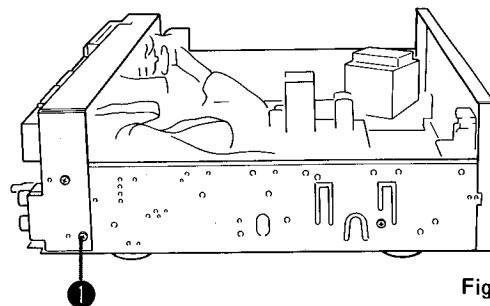

Fig. 6

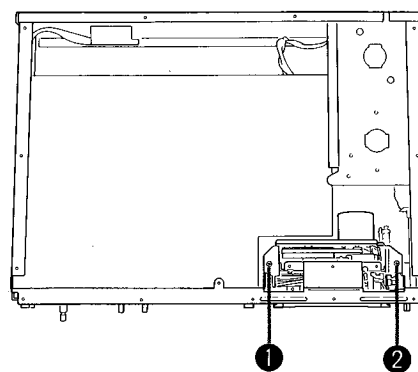

Fig. 7

**10 PLATE REMOVAL**

1. Remove the cassette tape mechanical assembly. (Refer to step 9 )
2. Unsolder the lead wires of LED with the plate.
3. Remove the screws 1 and 2 in Fig. 8 and then remove the plate.

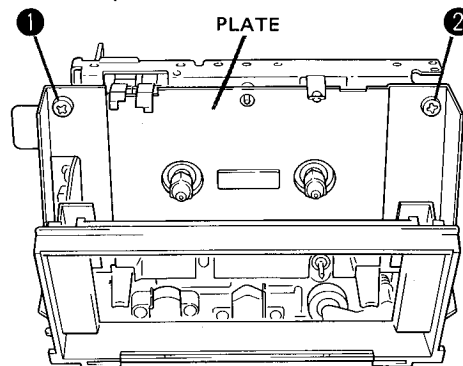

Fig. 8

**11 EJECT LOCK ARM REMOVAL**

1. Remove the plate. (Refer to step 10 )
2. Remove the springs 1 and 2 in Fig. 9 and remove the screw 3 in Fig. 9 and then remove the eject lock arm.

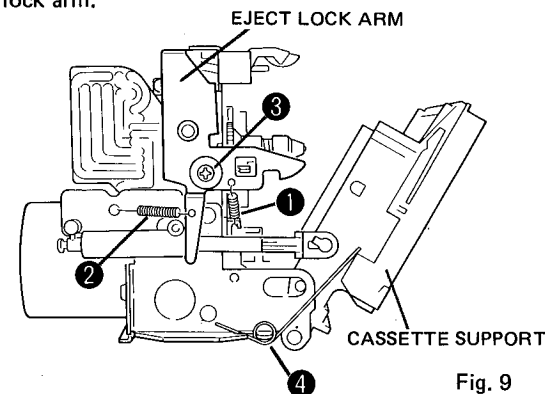

Fig. 9

**12 MICRO SWITCH REMOVAL**

1. Remove the eject lock arm. (Refer to step 11 )
2. Unsolder the lead wires which are connected to the micro switch.
3. Remove the screws 2 and 3 in Fig. 10 and then remove the micro switch.

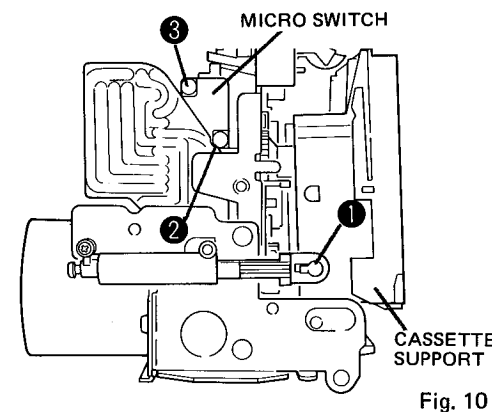

Fig. 10

**13 CASSETTE SUPPORT REMOVAL**

1. Remove the eject lock arm. (Refer to step 11 )
2. Remove the spring 4 in Fig. 9 and remove the joint part of damper 1 in Fig. 10 from cassette support.
3. Remove the screws 1 to 3 in Fig. 11 and remove the bracket and then remove the cassette support.

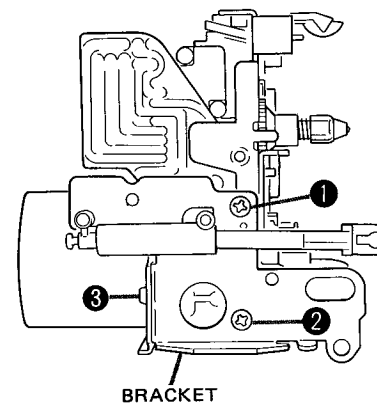

Fig. 11

**14 PINCH ROLLER AND HEAD REMOVAL**

1. Remove the cassette support. (Refer to step 13 )
2. Remove the lock washer 1 in Fig. 12 and remove the actuator of pinch roller spring 6 in Fig. 12 and then pull out the pinch roller.
3. Remove the screws 2 and 3 in Fig. 12 and then remove the erase head.
4. Remove the screws 4 and 5 in Fig. 12 and then remove the record/playback head.

\* Be careful not to lose the spring which are attached to the screws 2 and 4 in Fig. 12. Always adjust the azimuth after replacing the record/playback head. (Refer to alignment procedures)

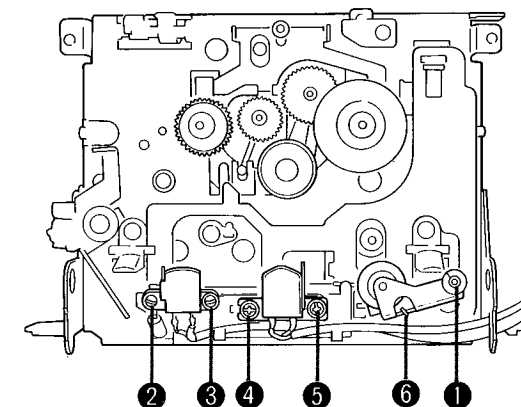

Fig. 12

**15 MOTOR AND BELT REMOVAL**

1. Remove the cassette tape recorder mechanical assembly. (Refer to step 9 )
2. Unsolder the lead wires which are connected to the motor.
3. Remove the screw 1 in Fig. 13 and remove actuators 2 and 3 when pulling down the motor bracket and then remove the motor bracket and remove main and sub belts.
4. Remove the screws 1 and 2 in Fig. 14 and then remove the motor.

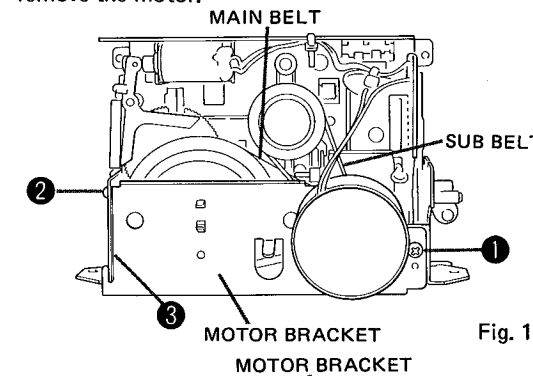

Fig. 13

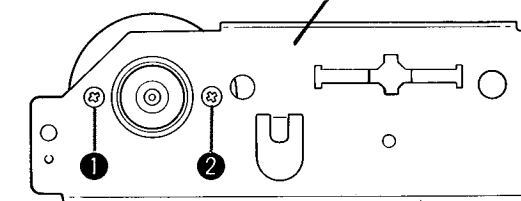

Fig. 14

### 5 DOLBY NR SWITCH P.C. BOARD REMOVAL

1. Remove the front panel assembly. (Refer to step 3.)
2. Remove the screw 17 in Fig. 4 (rear of plate assembly) and then remove dolby NR indicator P.C. board.
3. Remove the screws 3 and 4 in Fig. 4 and then remove the dolby NR switch P.C. board.  
\* Parts inspection and exchange would be possible in this condition.
4. When detaching the dolby NR switch P.C. board, unsolder the lead wires which are connected to the dolby NR switch P.C. board.

### 6 PLATE ASSEMBLY REMOVAL

1. Remove the dolby NR switch P.C. board. (Refer to step 5.)
2. Pull out the connector which is connected to LED level display assembly.
3. Unsolder the lead wires which are connected to reed switch P.C. board.
4. Remove the belt of the counter.
5. Remove the screws 5 to 7 in Fig. 4 and then remove the plate assembly.

### 7 LOGIC CONTROL P.C. BOARD REMOVAL

1. Remove the plate assembly. (Refer to step 6.)
2. Pull out the push buttons of auto repeat and rec. mute.
3. Disconnect the connectors from main P.C. board and connector panel of cassette mechanical assembly.
4. Unsolder the lead wires which are connected to the logic control P.C. board.
5. Remove the screws 8 to 11 in Fig. 4 and then remove the logic control P.C. board.

### 8 MAIN P.C. BOARD REMOVAL

1. Remove the meter amp. P.C. board and logic control P.C. board. (Refer to step 4 and 7.)
2. Unsolder the lead wires which are connected to the main P.C. board.
3. Pull out the knobs of bias fine trim and output level.
4. Remove the hexagonal nuts 12 to 15 and the screw 16 in Fig. 4.
5. Remove the screws 1 to 4 in Fig. 5 and the screw 1 in Fig. 6 and then pull out main P.C. board backward.

### CAUTIONS ON REMOVAL OF SWITCH SHAFT (AUTO REPEAT AND REC MUTE)

(REFER TO REF. NO. 207 OF PAGE 18)

Whenever it is necessary to remove the shaft from the push switch for repairing purpose, be careful not to pull out the shaft with the push switch being locked (a state being pushed in). That may damage the lock mechanism of the push switch. Be sure to push the switch once more to release the lock, if the push switch is locked.

### 9 CASSETTE TAPE RECORDER MECHANICAL ASSEMBLY REMOVAL

1. Remove the main P.C. board. (Refer to step 8.)
2. Unsolder the lead wires and disconnect the connector which are connected to the cassette tape recorder mechanical assembly.

3. Remove the screws 5 and 6 in Fig. 5 and 1 and 2 in Fig. 7 and then remove the cassette tape recorder mechanical assembly backward.

\* When mounting, tighten screws 1 and 2 in Fig. 7 first and then 5 and 6 in Fig. 5.

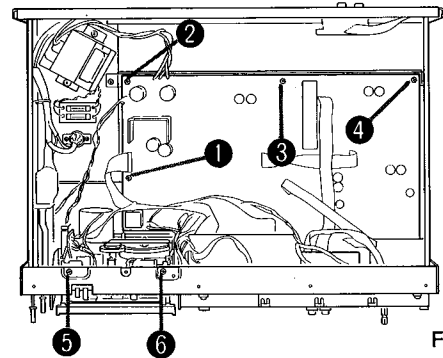

Fig. 5

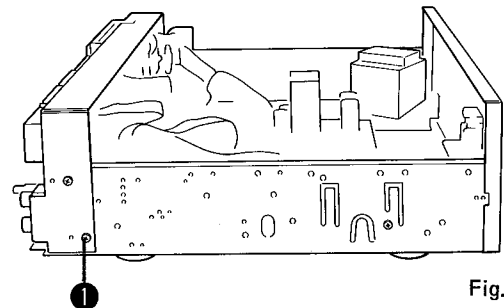

Fig. 6

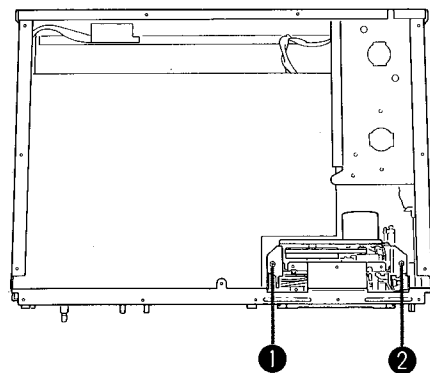

Fig. 7

### 10 PLATE REMOVAL

1. Remove the cassette tape mechanical assembly. (Refer to step 9.)
2. Unsolder the lead wires of LED with the plate.
3. Remove the screws 1 and 2 in Fig. 8 and then remove the plate.

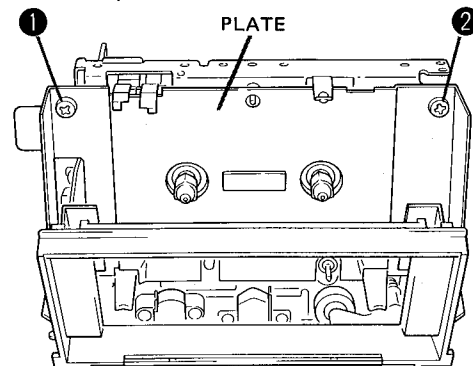

Fig. 8

1 and 2  
the recorder  
2 in Fig. 7

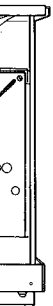

Fig. 5



Fig. 6



Fig. 7

ably. (Refer  
ate.  
8 and then



Fig. 8

**11 EJECT LOCK ARM REMOVAL**

1. Remove the plate. (Refer to step 10 )
2. Remove the springs 1 and 2 in Fig. 9 and remove the screw 3 in Fig. 9 and then remove the eject lock arm.

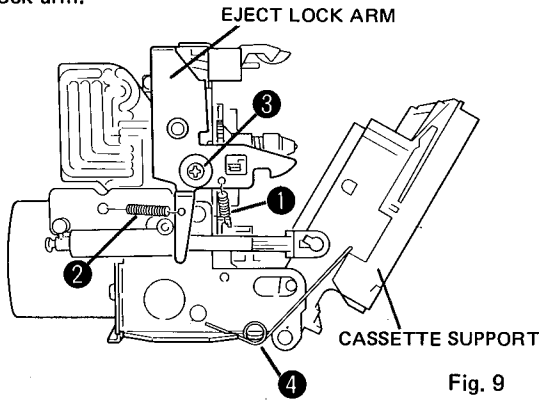

Fig. 9

**12 MICRO SWITCH REMOVAL**

1. Remove the eject lock arm. (Refer to step 11 )
2. Unsolder the lead wires which are connected to the micro switch.
3. Remove the screws 2 and 3 in Fig. 10 and then remove the micro switch.

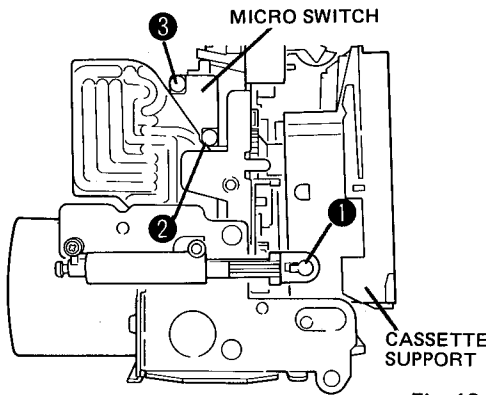

Fig. 10

**13 CASSETTE SUPPORT REMOVAL**

1. Remove the eject lock arm. (Refer to step 11 )
2. Remove the spring 4 in Fig. 9 and remove the joint part of damper 1 in Fig. 10 from cassette support.
3. Remove the screws 1 to 3 in Fig. 11 and remove the bracket and then remove the cassette support.

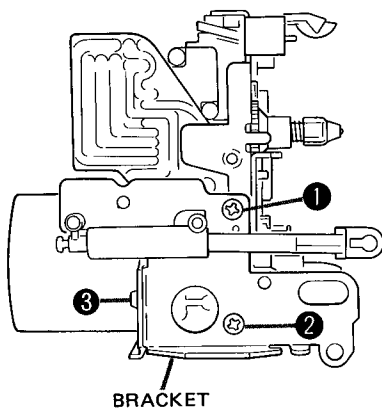

Fig. 11

**14 PINCH ROLLER AND HEAD REMOVAL**

1. Remove the cassette support. (Refer to step 13 )
  2. Remove the lock washer 1 in Fig. 12 and remove the actuator of pinch roller spring 6 in Fig. 12 and then pull out the pinch roller.
  3. Remove the screws 2 and 3 in Fig. 12 and then remove the erase head.
  4. Remove the screws 4 and 5 in Fig. 12 and then remove the record/playback head.
- \* Be careful not to lose the spring which are attached to the screws 2 and 4 in Fig. 12.  
Always adjust the azimuth after replacing the record/playback head. (Refer to alignment procedures)

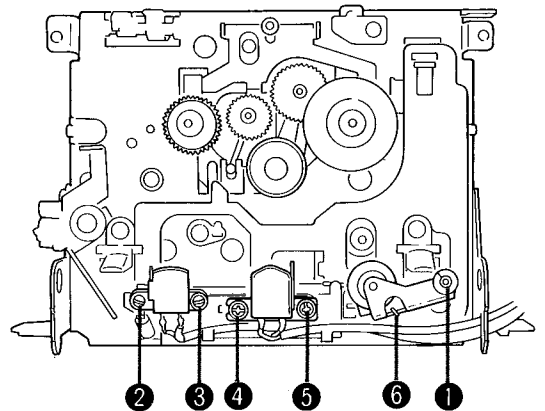

Fig. 12

**15 MOTOR AND BELT REMOVAL**

1. Remove the cassette tape recorder mechanical assembly. (Refer to step 9 )
2. Unsolder the lead wires which are connected to the motor.
3. Remove the screw 1 in Fig. 13 and remove actuators 2 and 3 when pulling down the motor bracket and then remove the motor bracket and remove main and sub belts.
4. Remove the screws 1 and 2 in Fig. 14 and then remove the motor.

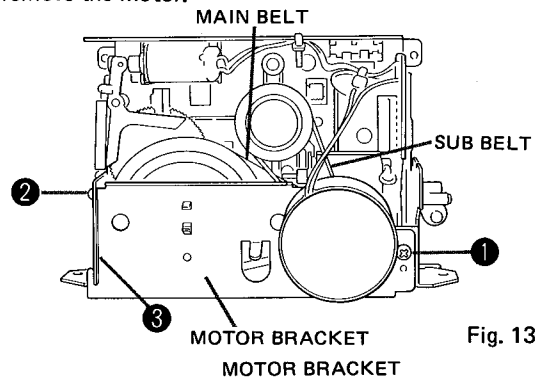

Fig. 13

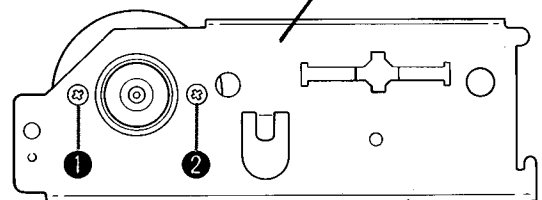

Fig. 14

**ALIGNMENT PROCEDURES**

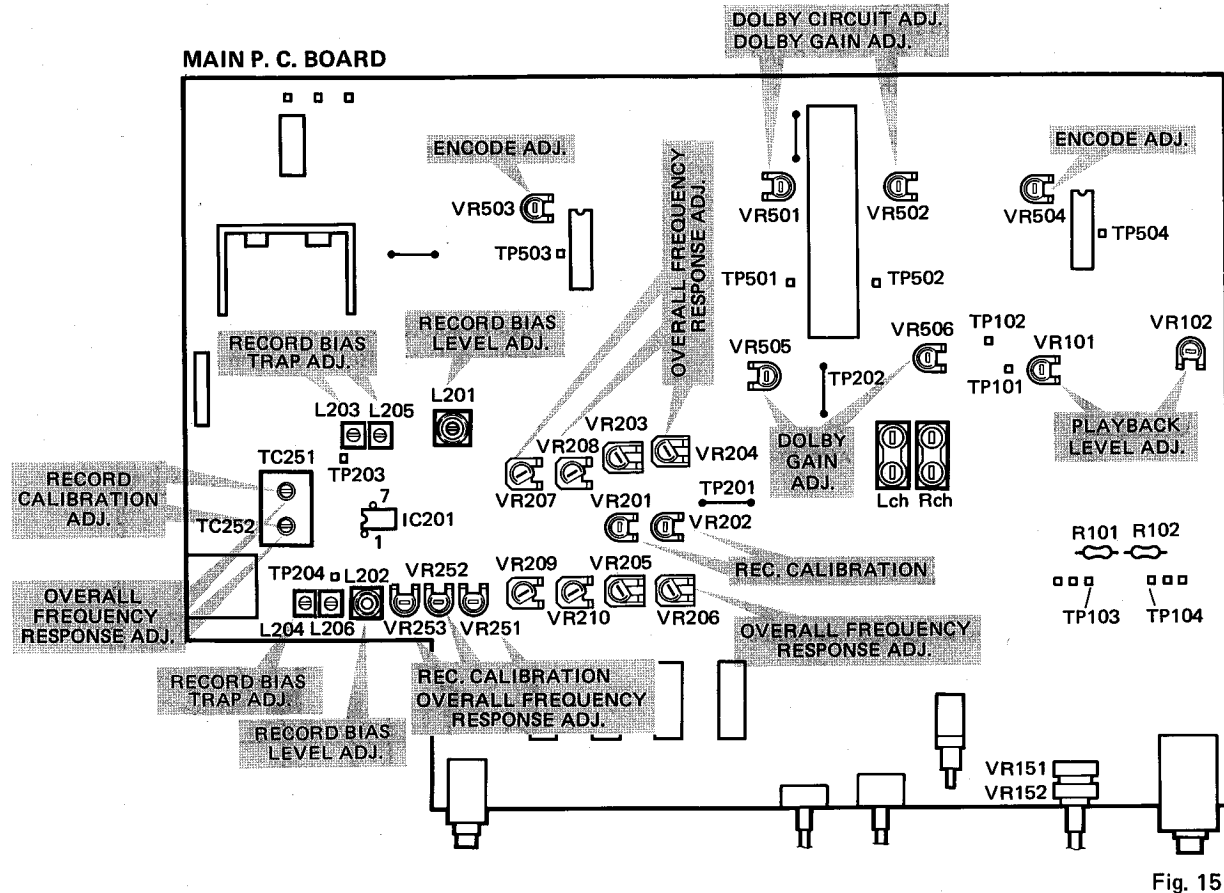

Fig. 15

**ELECTRICAL ADJUSTMENT**

**General conditions (unless otherwise noted)**

- Tape selector switch is LN position.
- Dolby NR switch is off position.
- MPX filter switch is off position.
- Input selector switch is line position.
- Bias fine trim control at center.
- Output level control at maximum.
- Adjustment for recording should be made after aging for at least 5 minutes.

**1. TAPE SPEED ADJUSTMENT**

- a) Connect a frequency counter to line out jacks.
- b) Play back the test tape (MTT-111D) and adjust the variable resistor built in the motor for 3kHz.

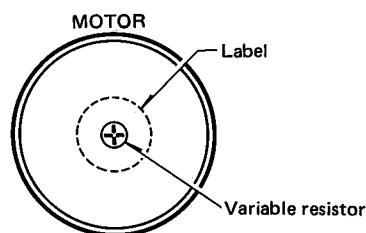

Fig. 16

**2. WOW FLUTTER TEST**

- a) Connect a wow flutter meter to line out jacks.
- b) Play back the test tape (MTT-111D) and confirm that wow flutter is within the specification.

**3. DOLBY CIRCUIT ADJUSTMENT**

Mid and high frequency response at dolby C may roll, so check and adjust as follows.

Measure the resistance of VR501 and VR502 (use ohm meter of first class). Classify the two class, a) more than 1.8 kΩ, b) less than 1.8 kΩ by the resistance of VR501 and VR502.

- a) When the resistance is more than 1.8 kΩ, set R529 and R530 to 1.5 kΩ.
- b) When the resistance is less than 1.8 kΩ, set R529 and R530 to 2.2 kΩ.

**4. DOLBY GAIN ADJUSTMENT**

- a) Insert a cassette without a tape.
- b) Connect a dual channel AC VTVM (A) to TP501 (left), TP502 (right) and ground, and connect a dual channel AC VTVM (B) to TP503 (left), TP504 (right) and ground.
- c) Apply a 700Hz (50mV) signal to both left and right line input jacks from an audio signal generator.
- d) Place unit in record mode.
- e) Adjust VR151 (left) and VR152 (right) to obtain a VTVM (A) reading of 775mV.
- f) Adjust VR505 (left) and VR506 (right) so that output on VTVM (B) becomes 775mV.
- g) Place unit in playback mode. Connect an audio signal generator to TP101 (left) and TP102 (right), and apply a 700Hz signal. Adjust generator input level for an output on the VTVM (B) of 775mV.
- h) Adjust VR501 (left) and VR502 (right) to obtain a VTVM (A) reading of 775mV.

**5. DOLBY ENCODE ADJUSTMENT**

- a) Insert a cassette without a tape.
- b) Connect a dual channel AC VTVM (A) to TP503 (left), TP504 (right) and ground, and connect a dual channel AC VTVM (B) to TP201 (left), TP202 (right) and ground.
- c) Connect an audio signal generator to both left and right line input jacks. Set the generator for a 700Hz (50mV) signal. Place unit in record mode.
- d) Adjust VR151 (left) and VR152 (right) to obtain a VTVM (A) reading of 23.5mV, and note the voltage obtained on the VTVM (B).
- e) Set the tape selector switch to all off position (button out). Set the dolby NR switch to on position and set the NR type selector switch to type C position. Adjust VR503 (left) and VR504 (right) so that output voltage becomes +11dB of voltage obtained on VTVM (B) at step d).
- f) Set the NR type selector switch to type B position. Confirm that the output voltage is +3 to 4 dB greater than the voltage obtained on VTVM (B) at step d).

**6. DOLBY DECODE TEST**

- a) Insert a cassette without a tape.
- b) Connect a dual channel AC VTVM to TP501 (left), TP502 (right) and ground.
- c) Connect an audio signal generator to TP101 (left), TP102 (right) and ground. Set the generator for a 700Hz signal. Place unit in playback mode. Adjust generator input level for an output on the VTVM of 83mV-11dB.
- d) Set the dolby NR switch to on position and set the NR type selector switch to type C position. Confirm that the voltage on VTVM becomes 83mV-11dB±0.5dB. When the voltage is out of rating, proceed with dolby encode adjustment again.

**7. METER ADJUSTMENT**

- a) Connect a dual channel AC VTVM to TP501 (left), TP502 (right) and ground.
- b) Connect an audio signal generator to both left and right line input jacks. Apply a 400Hz (100mV) signal. Record this signal on the normal blank test tape (XL-1).
- c) Adjust VR151 (left) and VR152 (right) so that the output on VTVM becomes 775mV.
- d) Adjust VR401 (left) and VR402 (right) so that 0dB of meter LED lights up.
- e) Set the output on VTVM to 775mV +5dB, 775mV -10dB and 775mV-20dB with VR151 (left) and VR152 (right). Confirm that LED lights up at each level accurately. When the LED does not light up accurately, proceed with the step d).

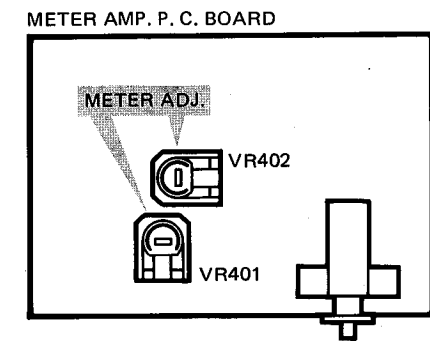

Fig. 17

**8. HEAD AZIMUTH ADJUSTMENT**

- a) Connect a dual channel AC VTVM to TP501 (left), TP502 (right) and ground.
- b) Play back the test tape (MTT-114) and adjust record/playback head azimuth adjustment screw so that the output on VTVM becomes maximum.

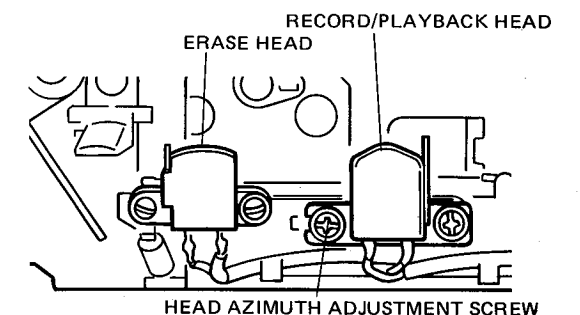

Fig. 18



# ALIGNMENT PROCEDURES

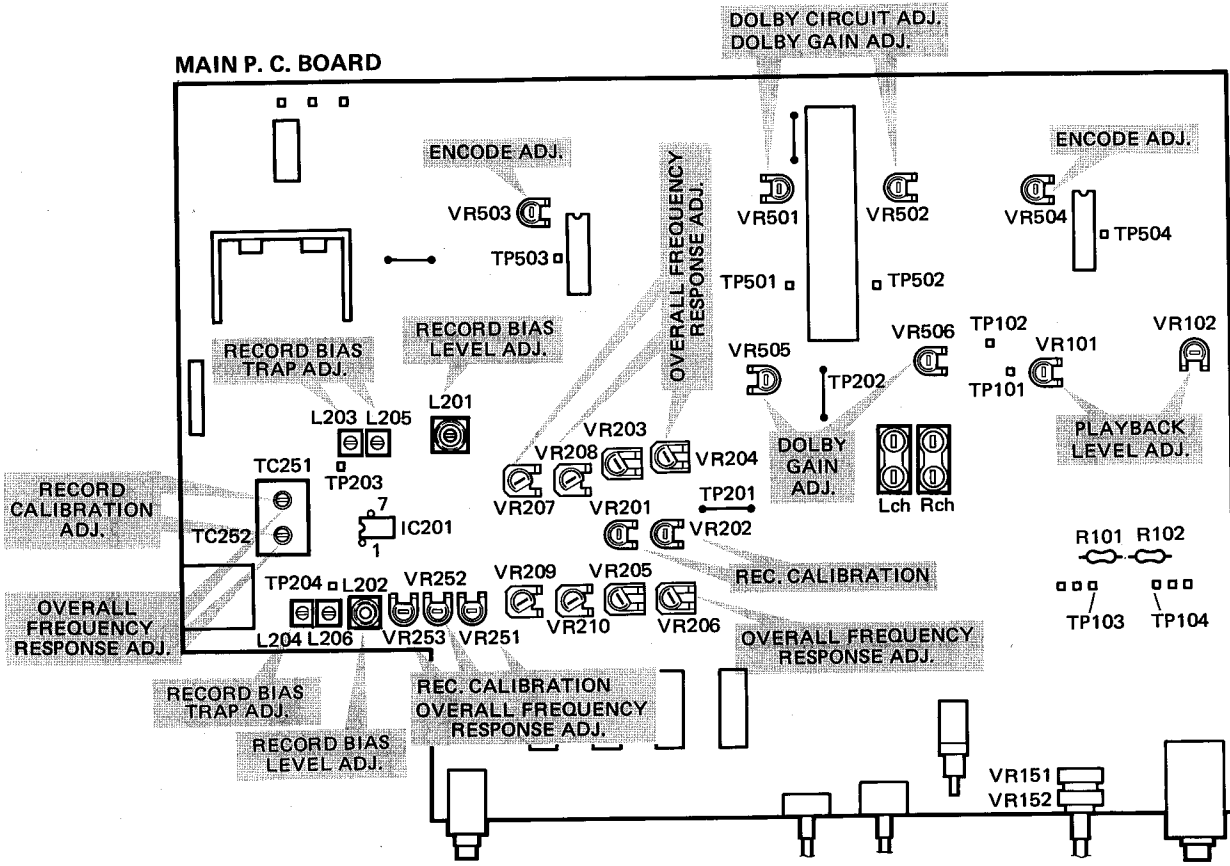

Fig. 15

## ELECTRICAL ADJUSTMENT

### General conditions (unless otherwise noted)

- Tape selector switch is LN position.
- Dolby NR switch is off position.
- MPX filter switch is off position.
- Input selector switch is line position.
- Bias fine trim control at center.
- Output level control at maximum.
- Adjustment for recording should be made after aging for at least 5 minutes.

### 1. TAPE SPEED ADJUSTMENT

- a) Connect a frequency counter to line out jacks.
- b) Play back the test tape (MTT-111D) and adjust the variable resistor built in the motor for 3kHz.

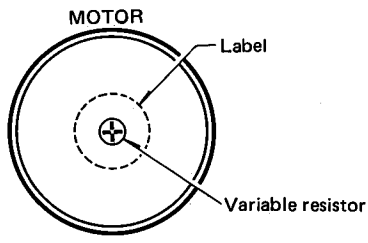

Fig. 16

### 2. WOW FLUTTER TEST

- a) Connect a wow flutter meter to line out jacks.
- b) Play back the test tape (MTT-111D) and confirm that wow flutter is within the specification.

### 3. DOLBY CIRCUIT ADJUSTMENT

Mid and high frequency response at dolby C may roll, so check and adjust as follows.

Measure the resistance of VR501 and VR502 (use ohm meter of first class). Classify the two class, a) more than 1.8 kΩ, b) less than 1.8 kΩ by the resistance of VR501 and VR502.

- a) When the resistance is more than 1.8 kΩ, set R529 and R530 to 1.5 kΩ.
- b) When the resistance is less than 1.8 kΩ, set R529 and R530 to 2.2 kΩ.

4. DOLBY  
a) Insert  
b) Conne  
(left),  
channel  
and gr  
c) Appl  
line in  
d) Place  
e) Adjust  
VTVM  
f) Adjust  
output  
g) Place  
genera  
apply  
an out  
h) Adjust  
VTVM

5. DOL  
a) Insert  
b) Conne  
(left),  
channel  
and gr  
c) Conne  
right  
(50m  
d) Adjus  
VTVM  
obtain  
e) Set th  
out).  
the M  
Adjust  
put v  
VTVM  
f) Set th  
Confi  
than

6. DOL  
a) Insert  
b) Conne  
TP50  
c) Conne  
TP10  
700H  
gener  
of 83  
d) Set th  
NR  
Confi  
83mV  
rating  
again

#### 4. DOLBY GAIN ADJUSTMENT

- a) Insert a cassette without a tape.
- b) Connect a dual channel AC VTVM (A) to TP501 (left), TP502 (right) and ground, and connect a dual channel AC VTVM (B) to TP503 (left), TP504 (right) and ground.
- c) Apply a 700Hz (50mV) signal to both left and right line input jacks from an audio signal generator.
- d) Place unit in record mode.
- e) Adjust VR151 (left) and VR152 (right) to obtain a VTVM (A) reading of 775mV.
- f) Adjust VR505 (left) and VR506 (right) so that output on VTVM (B) becomes 775mV.
- g) Place unit in playback mode. Connect an audio signal generator to TP101 (left) and TP102 (right), and apply a 700Hz signal. Adjust generator input level for an output on the VTVM (B) of 775mV.
- h) Adjust VR501 (left) and VR502 (right) to obtain a VTVM (A) reading of 775mV.

#### 5. DOLBY ENCODE ADJUSTMENT

- a) Insert a cassette without a tape.
- b) Connect a dual channel AC VTVM (A) to TP503 (left), TP504 (right) and ground, and connect a dual channel AC VTVM (B) to TP201 (left), TP202 (right) and ground.
- c) Connect an audio signal generator to both left and right line input jacks. Set the generator for a 700Hz (50mV) signal. Place unit in record mode.
- d) Adjust VR151 (left) and VR152 (right) to obtain a VTVM (A) reading of 23.5mV, and note the voltage obtained on the VTVM (B).
- e) Set the tape selector switch to all off position (button out). Set the dolby NR switch to on position and set the NR type selector switch to type C position. Adjust VR503 (left) and VR504 (right) so that output voltage becomes +11dB of voltage obtained on VTVM (B) at step d).
- f) Set the NR type selector switch to type B position. Confirm that the output voltage is +3 to 4 dB greater than the voltage obtained on VTVM (B) at step d).

#### 6. DOLBY DECODE TEST

- a) Insert a cassette without a tape.
- b) Connect a dual channel AC VTVM to TP501 (left), TP502 (right) and ground.
- c) Connect an audio signal generator to TP101 (left), TP102 (right) and ground. Set the generator for a 700Hz signal. Place unit in playback mode. Adjust generator input level for an output on the VTVM of 83mV-11dB.
- d) Set the dolby NR switch to on position and set the NR type selector switch to type C position. Confirm that the voltage on VTVM becomes 83mV-11dB±0.5dB. When the voltage is out of rating, proceed with dolby encode adjustment again.

#### 7. METER ADJUSTMENT

- a) Connect a dual channel AC VTVM to TP501 (left), TP502 (right) and ground.
- b) Connect an audio signal generator to both left and right line input jacks. Apply a 400Hz (100mV) signal. Record this signal on the normal blank test tape (XL -I).
- c) Adjust VR151 (left) and VR152 (right) so that the output on VTVM becomes 775mV.
- d) Adjust VR401 (left) and VR402 (right) so that 0dB of meter LED lights up.
- e) Set the output on VTVM to 775mV +5dB, 775mV -10dB and 775mV-20dB with VR151 (left) and VR152 (right). Confirm that LED lights up at each level accurately. When the LED does not light up accurately, proceed with the step d).

METER AMP. P. C. BOARD

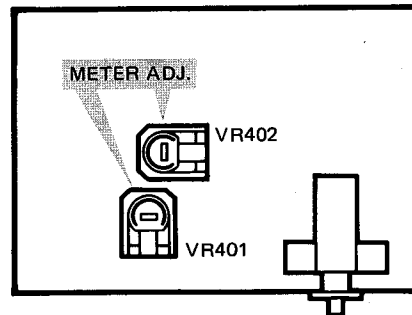

Fig. 17

#### 8. HEAD AZIMUTH ADJUSTMENT

- a) Connect a dual channel AC VTVM to TP501 (left), TP502 (right) and ground.
- b) Play back the test tape (MTT-114) and adjust record/playback head azimuth adjustment screw so that the output on VTVM becomes maximum.

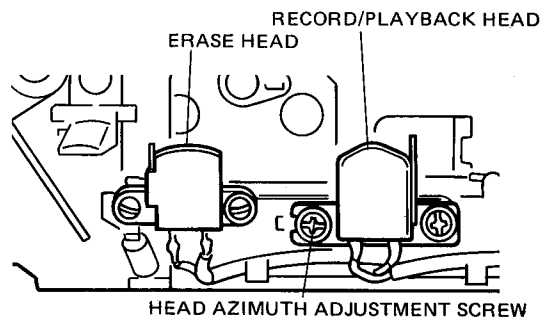

Fig. 18

\*When the maximum level point of R channel does not equal that of L channel, connect the oscilloscope as shown in Fig. 19 and proceed with azimuth adjustment so that L and R channels are in phase.

- Connect L channel tape out to "X (or V)" and R channel to "Y (or H)". Observe the lissajous waveform.
- Set L and R channels to monaural. Adjust vertical and horizontal gain so that the waveform becomes 45 degree.
- Adjust azimuth so that the measurement of "a" becomes maximum and the measurement of "b" becomes minimum against 45 degree line.

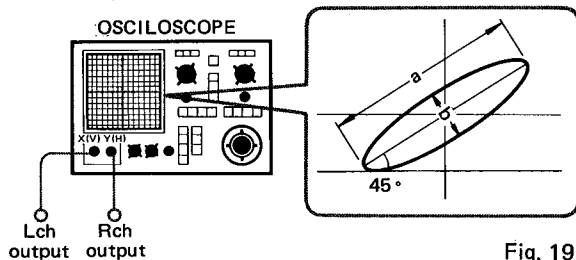

Fig. 19

### 9. PLAYBACK AMP. LEVEL ADJUSTMENT

- Connect a dual channel AC VTVM to TP501 (left), TP502 (right) and ground.
- Play back the test tape (MTT-150). Adjust VR101 (left) and VR102 (right) so that the output on VTVM becomes 775mV.

### 10. PLAYBACK EQUALIZER FREQUENCY CHARACTERISTIC TEST

- Connect a dual channel AC VTVM to TP501 (left), TP502 (right) and ground.
- Play back the test tape (MTT-216) and note the frequency response obtained on the VTVM. Confirm that frequency response is within the range as shown in Fig. 20.
- Set tape selector switch to FeCr position.
- Play back the test tape (MTT-316) and note the frequency response obtained on the VTVM. Confirm that frequency response is within the range as shown in Fig. 20.

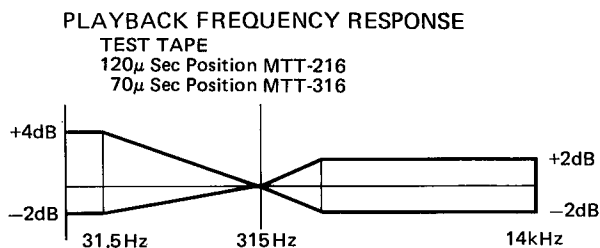

Fig. 20

### 11. ERASE FREQUENCY TEST

- Set tape selector switch to metal position.
- Place unit in record mode by using metal blank test tape (AC-711).
- Connect a frequency counter to TP103 and ground, and confirm that the frequency becomes 105kHz $\pm$  5kHz.

### 12. RECORD BIAS TRAP ADJUSTMENT

- Set tape selector switch to metal position.
- Connect a dual channel AC VTVM (A) to TP103 (left), TP104 (right) and ground, and connect a dual channel AC VTVM (B) to TP203 (left), TP204 (right) and ground.
- Place unit in record mode by using metal blank test tape (AC-711) and adjust TC251 (left) and TC252 (right) so that the bias level on VTVM (A) becomes about 100mV.
- Adjust L205 (left) and L206 (right) so that trap level on VTVM (B) becomes minimum.
- Adjust L203 (left) and L204 (right) so that bias level on VTVM (A) becomes maximum.
- Again adjust and confirm step d).

### 13. RECORD CALIBRATION TEMPORARY ADJUSTMENT

- Connect a dual channel AC VTVM across R101 (left) and across R102 (right).
- Place unit in record mode.
- Adjust TC251 and TC252 so that bias level becomes about 88mV with metal position by using metal blank test tape (AC-711).
- Adjust VR253 so that bias level becomes about 44mV with CrO<sub>2</sub> position by using CrO<sub>2</sub> blank test tape (AC-512).
- Adjust VR252 so that bias level becomes about 47mV with FeCr position by using FeCr blank test tape (CS-30).
- Adjust VR251 so that bias level becomes about 31mV with LN position by using normal blank test tape (XL-I).
- Connect a dual channel AC VTVM to TP501 (left), TP502 (right) and ground.
- Connect an audio signal generator to both left and right line input jacks. Set the generator for a 400Hz (100mV) signal.
- Set tape selector switch to LN position. Place unit in record mode. Adjust VR151 (left) and VR152 (right) so that the output on VTVM becomes 775mV.
- Recording this signal on the normal blank test tape (XL-I) and playing it, adjust VR201 (left) and VR202 (right) by repeating record and playback so that the output on VTVM becomes 775mV.
- Confirm that the playback levels for FeCr, CrO<sub>2</sub> and metal position as it is with LN position by using each test tapes (CS-30, AC-512 and AC-711).

#### 14. RECORD EQUALIZER PEAKING ADJUSTMENT

- Connect a dual channel AC VTVM (A) to TP501 (left), TP502 (right) and ground, and connect a dual channel AC VTVM (B) to pin 7 (left) and pin 1 (right) of IC201 and ground.
- Connect an audio signal generator to both left and right line input jacks. Place unit in record mode by using normal blank test tape (XL-I). Adjust generator input level for an output on the VTVM (A) of 775mV-25dB.
- Apply a 23kHz signal and adjust L201 (left) and L202 (right) so that the output level on the VTVM (B) becomes maximum. (Adjust with a nonmetal screw driver.)
- Vary the generator frequency from 20kHz to 26kHz. Confirm that the frequency at which the output level becomes maximum is within  $23\text{kHz} \pm 0.2\text{kHz}$ . If the frequency becomes out of range, readjust step c).

#### 15. RECORD/PLAYBACK EQUALIZER FREQUENCY CHARACTERISTIC ADJUSTMENT

- VR203 to VR210 are set temporarily as shown in Fig. 21.

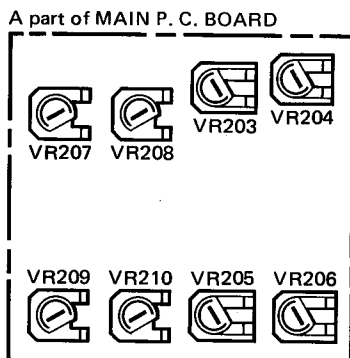

Fig. 21

- Connect a dual channel AC VTVM (A) to TP501 (left), TP502 (right) and ground, and connect a dual channel AC VTVM (B) to both left and right line output jacks.
- Connect an audio signal generator to both left and right line input jacks. Adjust the generator input level for an output on VTVM (A) of 775mV -25dB, when the unit is in recording mode.
- Set tape selector switch to CrO<sub>2</sub> position.
- Record the signal from generator on to a CrO<sub>2</sub> blank test tape (AC-512) varying the generator frequency from 20Hz to 30kHz.
- Play back the CrO<sub>2</sub> tape recorded above, note the frequency response obtained on the VTVM (B) and compare to Fig. 22.
- If the above frequency response is not within the CrO<sub>2</sub> area on Fig. 22, adjust TC251 (left), TC252 (right) and VR253 slightly. Repeat steps e) and f) until playback frequency response on the VTVM (B) is adjusted within the range as shown in Fig. 22.

- Set tape selector switch to metal position.
- Record the signal from generator on to a metal blank test tape (AC-711) varying the generator frequency from 20Hz to 30kHz.
- Play back the metal tape recorded above and note the frequency response obtained on the VTVM (B).
- If the above frequency response is not within the METAL area of Fig. 22, adjust VR207 (left) and VR208 (right) slightly. Repeat steps i) and j) until playback frequency response on the VTVM (B) is adjusted within the range as shown in Fig. 22.
- Set tape selector switch to FeCr position.
- Record the signal from generator on to a FeCr blank test tape (CS-30) varying the generator frequency from 20Hz to 30kHz.
- Play back the FeCr tape recorded above and note the frequency response obtained on the VTVM (B).
- If the above frequency response is not within the FeCr area of Fig. 22, adjust VR252 (left) and VR206 (right) slightly. Repeat steps m) and n) until playback frequency response on the VTVM (B) is adjusted within the range as shown in Fig. 22.
- Set tape selector switch to LN position.
- Record the signal from generator on to a normal blank test tape (XL-I) varying the generator frequency from 20Hz to 30kHz.
- Play back the normal tape recorded above and note the frequency response obtained on the VTVM (B).
- If the above frequency response is not within the LN area of Fig. 22, adjust VR251 (left) and VR204 (right) slightly. Repeat steps q) and r) until playback frequency response on the VTVM (B) is adjusted within the range as shown in Fig. 22.

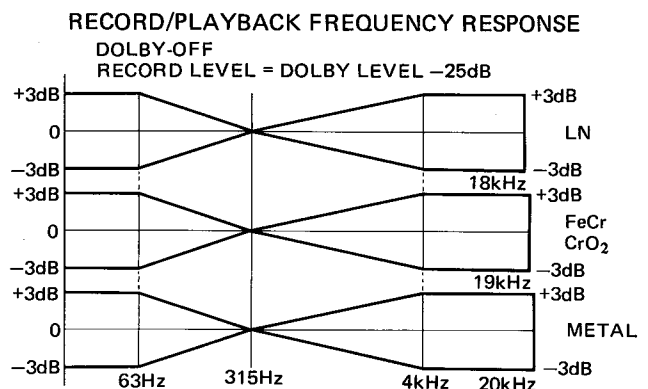

Fig. 22

- LEVEL DEVIATION between L and R channels  
The maximum level deviation should be within 3dB at 315 ~12.5kHz.

## 16. RECORD CALIBRATION ADJUSTMENT

- Connect a dual channel AC VTVM to TP501 (left), TP502 (right) and ground.
- Connect an audio signal generator to both left and right line input jacks. Set the generator for a 400Hz (100mV) signal.
- Place unit in record mode and adjust VR151 (left) and VR152 (right) so that the output on VTVM becomes 775mV.
- Recording this signal on the normal blank test tape (XL-I) and playing it, adjust VR201 (left) and VR202 (right) by repeating record and playback so that the output on VTVM becomes 775mV.
- Confirm that playback levels for FeCr, CrO<sub>2</sub> and metal position as it is with LN position by using each test tapes (CS-30, AC-512 and AC-711).

## 17. RECORD/PLAYBACK EQUALIZER FREQUENCY CHARACTERISTIC FOR DOLBY NR-B AND NR-C SYSTEM

After adjusting step 3 to 16, confirm that the frequency response is within the range as shown in Fig. 23 and 24 with dolby NR on.

### RECORD/PLAYBACK FREQUENCY RESPONSE

DOLBY-C ON  
RECORD LEVEL = DOLBY LEVEL -25dB

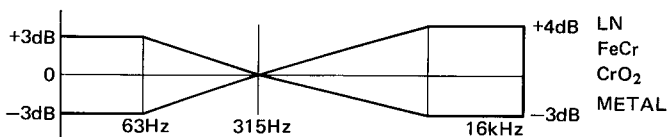

Fig.23

### RECORD/PLAYBACK FREQUENCY RESPONSE

DOLBY B-ON  
RECORD LEVEL = DOLBY LEVEL -25dB

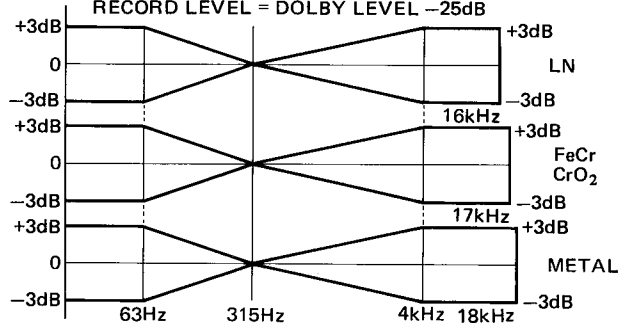

Fig. 24

- LEVEL DEVIATION between L and R channels**  
 The maximum level deviation should be within 3dB at 315 ~ 12.5kHz.

## MECHANISM ADJUSTMENT AND CONFIRMATION

### ■ HEAD

#### ● HEIGHT

- Attach the M-300 head gauge plate.
- Inspect the height of the head with an adjustment chip attached to the gauge plate at playback mode.
- The adjustment chip attached to the gauge plate should not hit the tape guide of record/playback and erase heads.

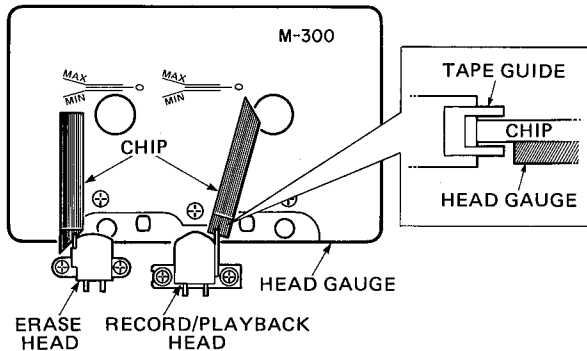

#### ● FRONT AND REAR POSITION

- Attach the M-300 head gauge plate.
- Attach the adjustment chip attached to the gauge plate to the center of the head and read the scale on the plate.
- The scale should be within MIN and MAX of the M-300 head gauge at both record/playback and erase heads.
- If the scale is not within the specified range, adjust it by loosening the screw fixing each head.
- After adjustment, apply screw lock paint.

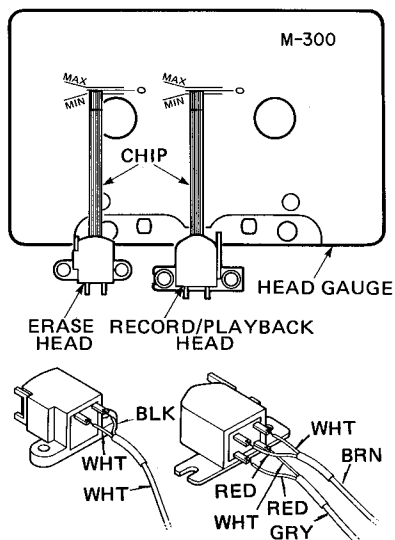

### ■ PINCH ROLLER

#### ● TAPE RUNNING

- Insert a mirror cassette tape and set to the playback mode.
- The tape should not be curled at the tape guide of the record/playback and erase heads.

**NOTES:** Confirm that grease or foreign substance adhere to the rubber of the pinch roller, and that no flaw is on the pinch roller.

#### ● PINCH ROLLER PRESSURE

- With unit in playback mode, put a tension gauge as shown in the illustration and add the load to arrow direction and measure the value at which the rotation of the pinch roller stops.
- Confirm that the load is between 250g and 350g when the pinch roller leaves the capstan.

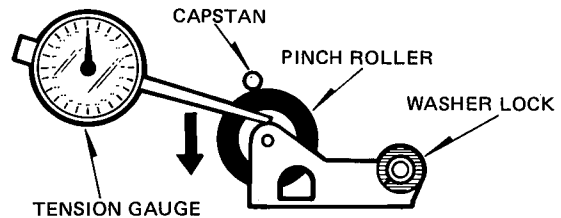

### ■ CLUTCH ASSEMBLY

- Confirm that clutch assembly operates smoothly after replacing.
- Insert the C-60 tape and when stop button is depressed at fast forward/rewind end, clutch assembly return to the neutral position.

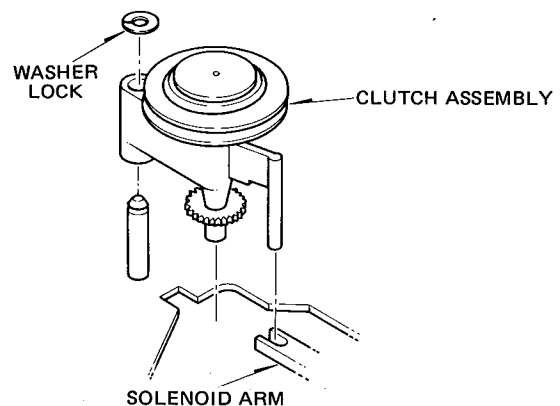

## ■ MICRO SWITCH

### ● CASSETTE PACK DETECT SWITCH

- Confirm that the switch operates when the cassette pack (the cassette pack is measurement 63.5mm or a MAZ-0184-C gauge) is set to the right position.
- Confirm that the switch changes to off when you return the switch (SW. ARM) at on position slowly.

### ● MIS-ERASE PROTECT SWITCH

- Confirm that the switch operates with a cassette tape which has an actuator for mis-erase protect (a tape which is measurement 62.9mm or a MAZ-0184-C gauge).
- Confirm that the switch changes to off when you return the switch (REC. ARM) at on position.

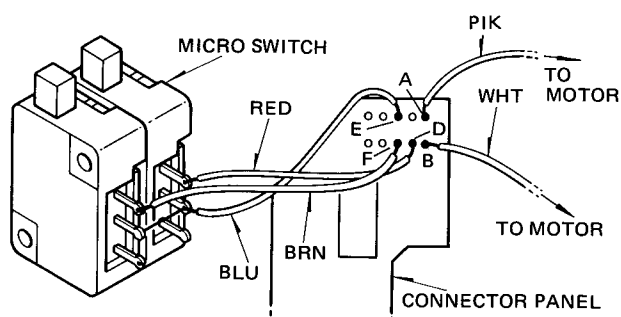

## ■ BELT

Confirm that the belt does not fall off when you force the fly wheel to stop with your hand while it is rotating.

## ■ AIR DAMPER

- Confirm that cassette lid opens smoothly and that no unusual sound is heard while opening or closing the cassette lid when the eject button is depressed.
- Confirm that the eject lever does not touch the chassis or the damper, etc. and it operates smoothly.
- Confirm that the eject button can't be depressed during playback.
- Adjust the screw of the damper with a  $\oplus$  screw driver so that the speed which is necessary for the cassette support to fully open with the eject lock arm becomes more than one second.

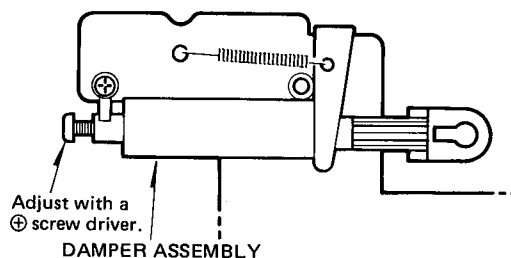

BLOCK DIAGRAM

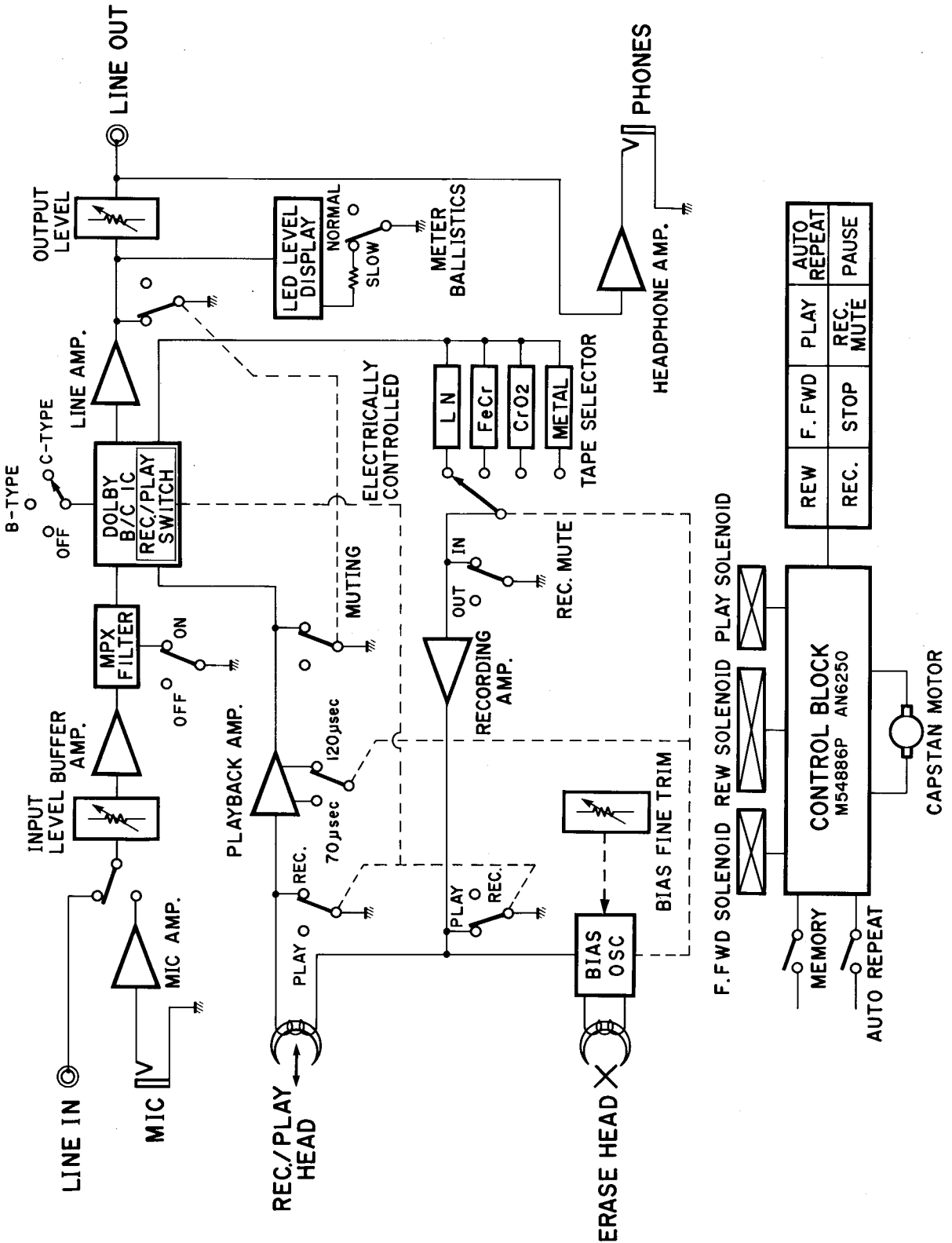

REW	F. FWD	PLAY	AUTO REPEAT
REC.	STOP	REC. MUTE	PAUSE



## CIRCUIT DESCRIPTION

### ● PLAYBACK MODE (R ch)

The output of record/playback head is fed to base of playback amp. (Q102) and amplified. The output of playback amp. is fed to 15 pin of the dolby IC (IC502). At Dolby-B mode, the noise reduction is done with one block of dolby IC.

At Dolby-C mode, further the other block is used.

After noise reduction, the signal is amplified in the line amp. (Q302, Q304, Q306, Q308) and through output level variable resistor, line out signal is gained.

### ● RECORDING MODE (L ch)

Mic. input is fed to the base of mic amp. (Q151). The output of mic amp. and line in input are fed to 15 pin of dolby IC (IC501) through the buffer amp. (Q501, Q503) and MPX filter. After noise reduction, recording signal is fed to the record amp. (IC201).

The output of record amp. (IC201) is added to the bias current from bias OSC block and fed to the record/play-back head.

### ● MUTING

To mute the output of the line amp. Q301, 303, 305, 307 (L ch) and Q302, 304, 306, 308 (R ch), the muting control voltage is taken out from 9 pin of the tape deck controller (IC801) and mutes at "High" level. Q717 (L ch) and Q718 (R ch) become on.

### ● RECORD/PLAYBACK CONTROL SWITCH TABLE

MODE	Q701 Q703	Q705	Q715	Q717	Q720	Q723
PLAY- BACK IC801 PIN9	ON	OFF	OFF	OFF	OFF	ON
RECORD IC801 PIN15	OFF	ON	ON	OFF	ON	OFF

## IC FUNCTIONAL BLOCK DIAGRAM

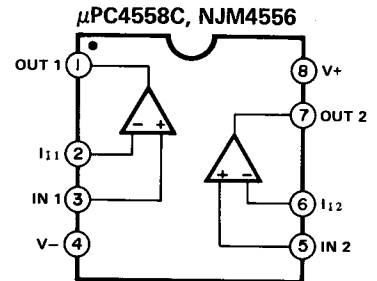
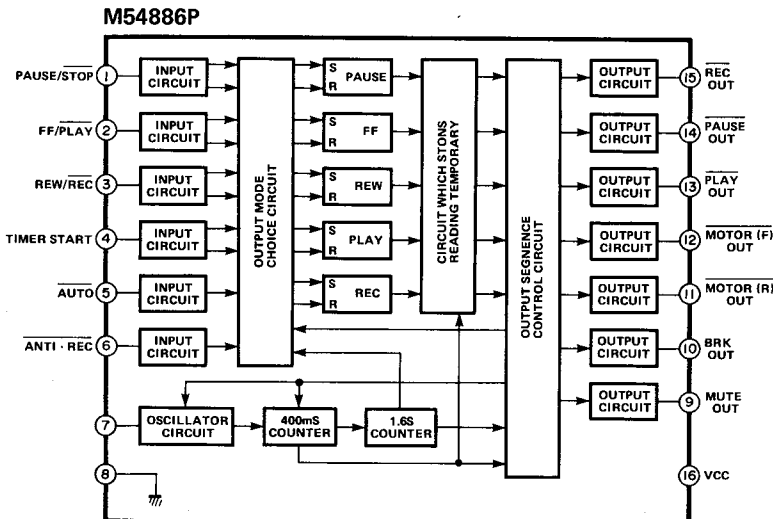
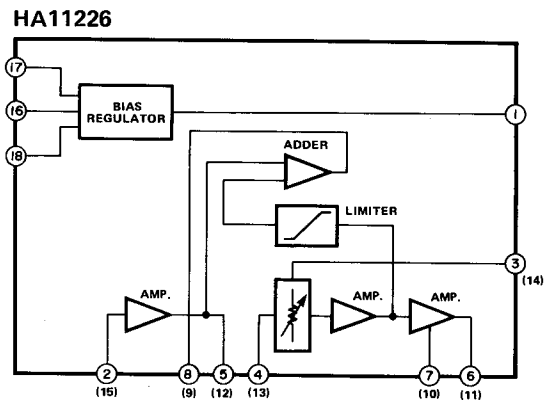
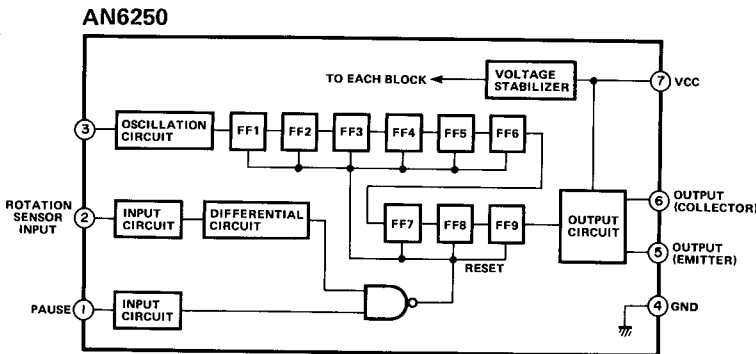

# TIMING CHART

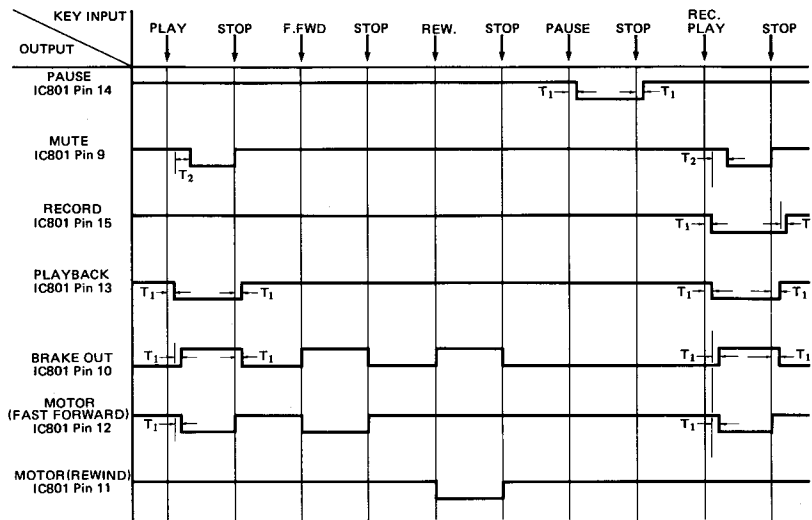

Fig. 1

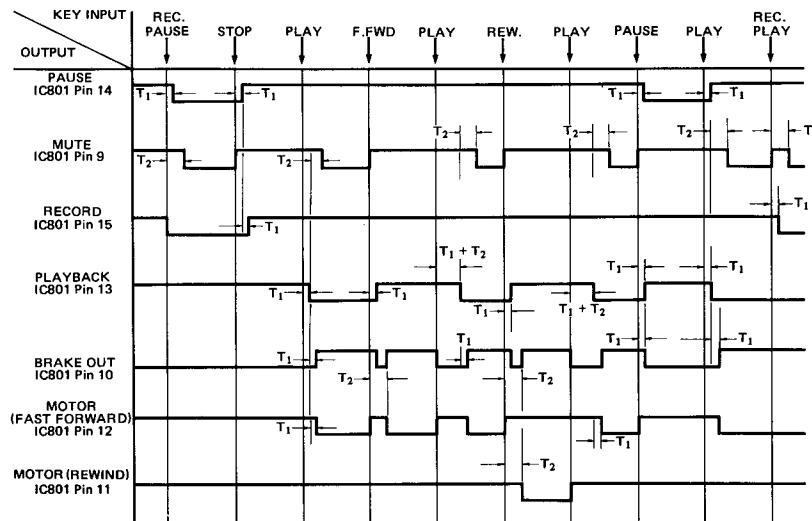

Fig. 2

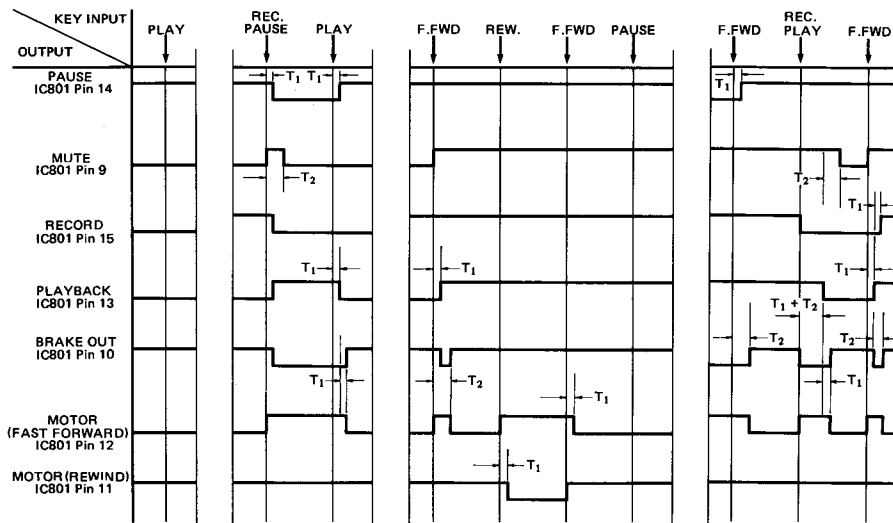

Fig. 3

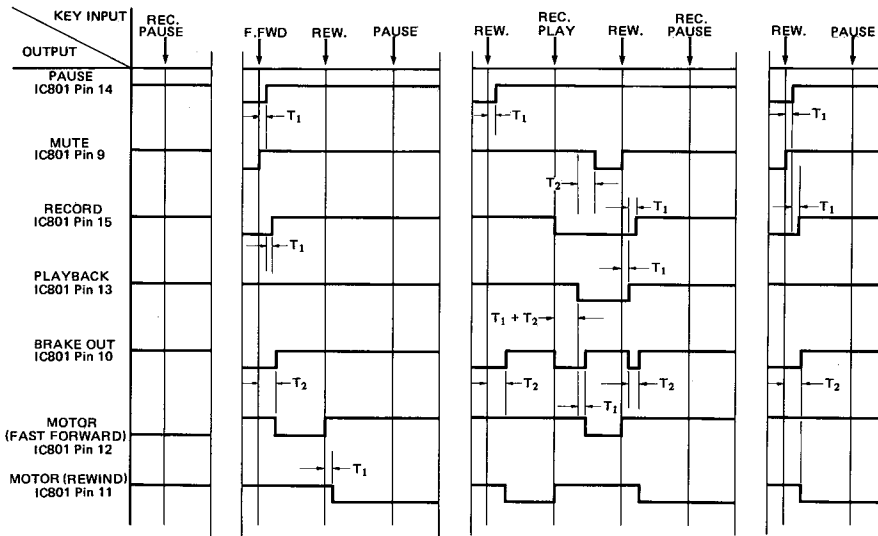

Fig. 4

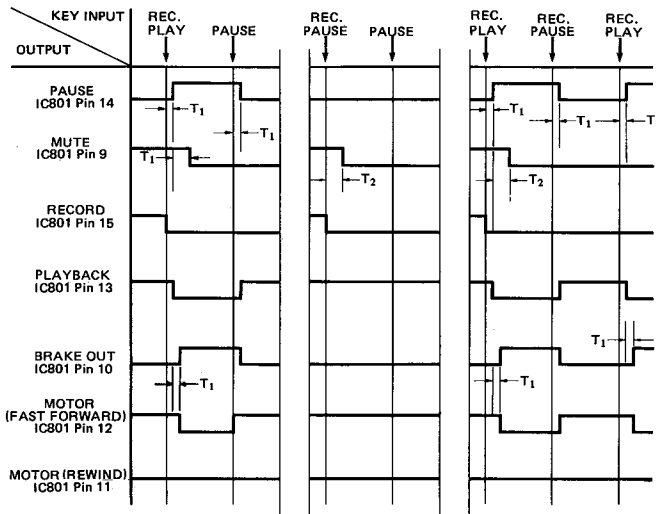

Fig. 5

**NOTE**  
After the power switch is pushed on, the unit remains in stop mode for about 1.6 second. After that, it operates according to each input key as shown figure. During this 1.6 second all input keys are ineffective.

● **AUTO REPEAT TIMING CHART**

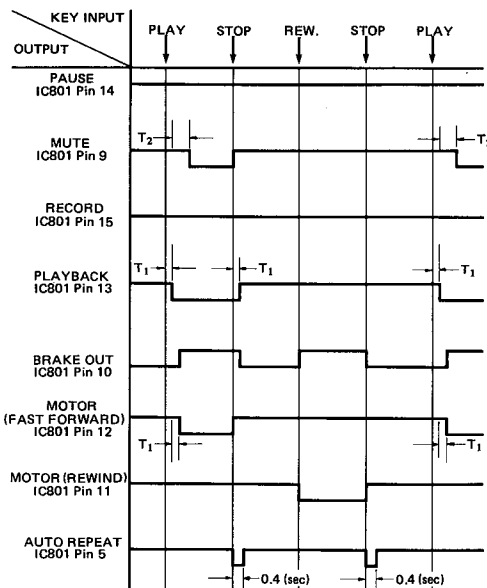
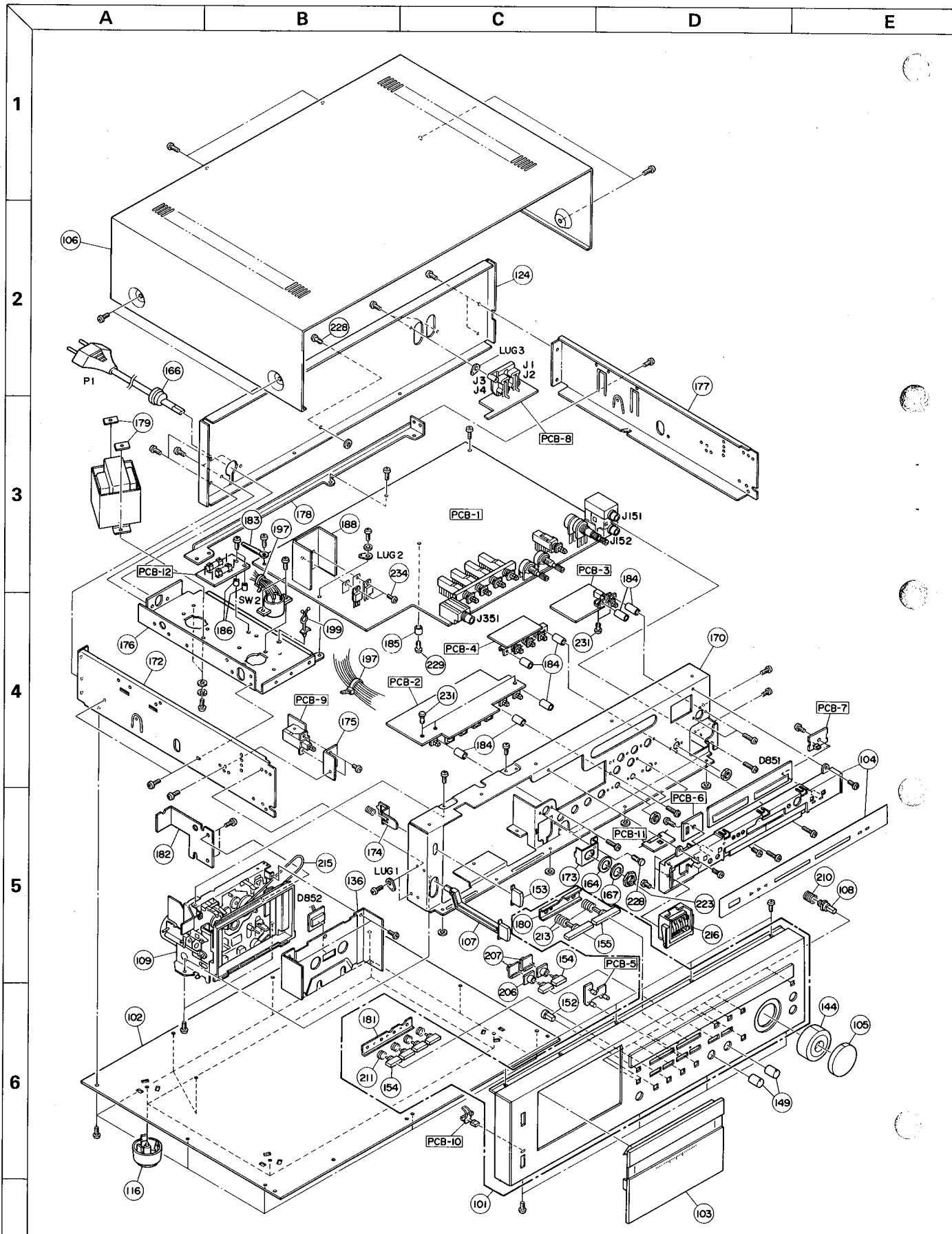

Fig. 6

$T_1 = 61$  (msec)  
 $T_2 = 400$  (msec)

GENERAL UNIT EXPLODED VIEW



## GENERAL UNIT PARTS LIST

Ref. No.	Part No.	Description
101	A443-CD201A	Front Panel Assembly
102	A423-CD201A	Cabinet Bottom Assembly
103	A452-CD201A	Door Assembly
104	A514-CD201A	Plate Assembly, L.E.D.
105	A634-CD201A	Knob Assembly, Input Level (L)
106	A414-CD201A	Cabinet Top Assembly
107	A662-CD201A	Push Button Assembly, Power
108	A662-CD201B	Push Button Assembly, Memory, Tape Selectors, Dolby NR System Selector, MPX Filter, Input Selector, Meter Ballistics
109	3112-10801	Cassette Tape Recorder Mechanical Assembly
116	1319-0139	Foot
124	1424-07004	Cabinet Back
136	1514-08801	Plate
144	1630-01801	Knob, Input Level (R)
149	1634-02701	Knob, Bias Fine Trim, Output Level
152	1662-05401VN	Push Button, Reset
153	1662-05501VN	Push Button, Eject
154	1662-08502VN	Push Button, Rew, F.FWD, Rec., Pause, Auto Repeat, Rec. Mute
155	1662-08602VN	Push Button, Stop, Play
164	2111-1356	Felt, Headphones Jack
166	2114-415027	Bushing, AC Line Cord
167	2114-72167	Bushing, Headphones Jack
170	2211-7222	Chassis
172	2219-7655	Bracket
173	2219-7809	Bracket
174	2219-7810	Bracket
175	2219-7811	Bracket
176	2219-7812	Bracket
177	2219-7813	Bracket
178	2219-7821	Bracket
179	2219-7091	Bracket
180	2219-7818	Bracket
181	2219-7819	Bracket
182	2219-7856	Bracket
183	2218-7001	Holding Bracket
184	2132-01401	Spacer
185	2132-7016	Spacer
186	2132-01701	Spacer
188	2222-7124	Heat Sink
197	2240-7120	Holder
199	2240-7048	Holder
206	2601-7098	Shaft
207	2601-7102	Shaft
210	2651-210188	Spring
211	2651-210192	Spring
213	2651-210197	Spring
215	2642-01444	Belt
216	3131-015014	Counter
223	2440-61	Special Nut
228	2459-3003511	Rivet
229	2459-3008011	Rivet
231	2459-3004511	Rivet
234	2320-7004	Special Screw (+)

# CASSETTE MECHANISM EXPLODED VIEW

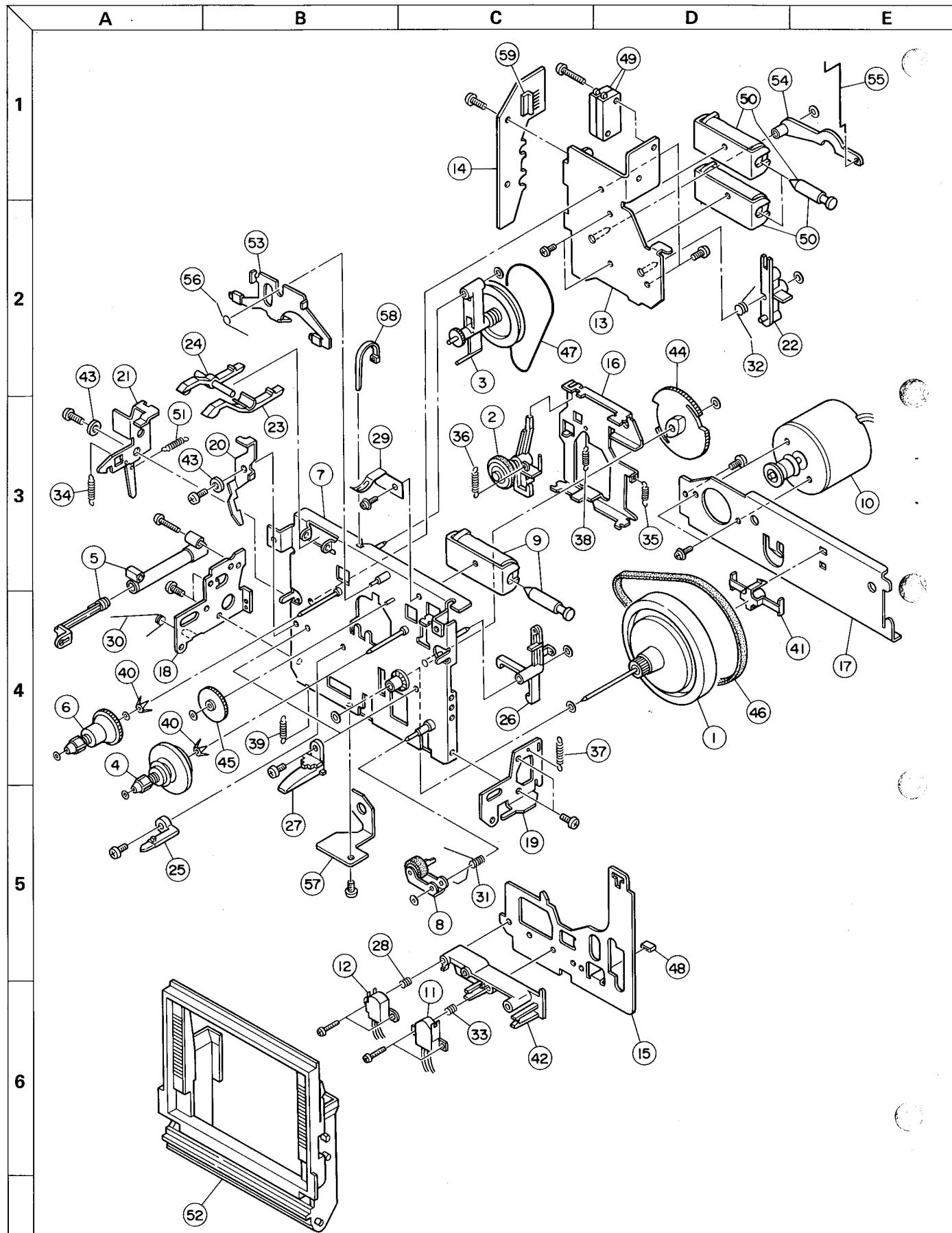

## CASSETTE MECHANISM PARTS LIST

Ref. No.	Part No.	Description
1	FP467-11	Flywheel Assembly
2	FP469-12	Idler Assembly
3	FP470-11	Clutch Assembly
4	FR12N-11	Take-up Reel Assembly
5	FP472-11	Damper Assembly
6	FR12P-11	Supply Reel Assembly
7	F011-132	Chassis
8	F014-053	Pinch Roller
9	PKA16108	Solenoid
10	F064-093	Motor
11	F029-116	Head, Record/Playback
12	F030-059	Head, Erase
13	F214-015	Bracket, Solenoid
14	FP11N-11	Connector Panel
15	FR345-12	Head Base
16	FR346-11	Assist Base
17	FR347-11	Bracket, Motor
18	FR349-13	Bracket, Damper
19	FR350-12	Bracket, Door
20	FR352-11	Safety Lever
21	FC11H-12	Eject Lock Arm
22	FR355-14	FF Solenoid Arm
23	FR356-14	Switch Arm
24	FD17T-12	Record Arm
25	FR358-12	Reference Guide
26	FR359-12	Play Solenoid Arm
27	FR360-12	Cassette Guide
28	FK572-12	Spring, Azimuth
29	FK551-13	Spring, Cassette
30	FK568-11	Spring, Door
31	FK569-12	Spring, Pinch Roller
32	FK570-12	Spring, Solenoid Bracket
33	FK572-11	Spring, Azimuth
34	FK573-11	Spring, Eject Lock Arm
35	FK574-12	Spring, Assist Base
36	FK575-11	Spring, Play Idler
37	FK576-12	Spring, Play Solenoid Arm
38	FK577-12	Spring, Assist Base
39	FK578-12	Spring, Head Base Hold
40	FK579-11	Spring, Back Tension
41	FM281-11	Spacer, Flywheel
42	FM283-13	Spacer, Head
43	FM296-11	Spacer
44	FN153-11	Play Gear
45	FN154-13	Idler Gear
46	FP462-11	Main Belt
47	FP463-11	Sub Belt
48	FP464-11	Cushion
49	FE173-11	Micro Switch
50	PKA16106	Solenoid
51	FK11C-11	Spring, Eject Lock Arm
52	F027-055	Cassette Support
53	F028-025	Brake
54	FD12W-11	Brake Arm
55	FK11Y-12	Rod, Brake Arm
56	FK12A-11	Spring, Brake
57	FC25D-11	Belt Guide
58	FH126-11	Holder
59	KY130-11	Connector

## ELECTRICAL PARTS LIST

Ref. No.	Part No.	Description
<b>CHASSIS MISCELLANEOUS</b>		
P1	4161-7256	AC Line Cord
T1	5584-701392	Power Transformer
SW2	4411-104746	Rotary Switch, Voltage Selector
D851	5623-LT1042	LED Display Assembly
D852	5637-SLF301C	L.E.D., SLF301C, Yellow
J401	4163-051302	Connector with Lead Wire, 5-Pin
J701	4163-093001	Connector with Lead Wire, 9-Pin
J801	4163-082002	Connector with Lead Wire, 8-Pin
JM151	4242-054302	Jumper Lead, 5-Wire
JM501	4242-051802	Jumper Lead, 5-Wire
JM502	4242-071602	Jumper Lead, 7-Wire
JM551	4242-062002	Jumper Lead, 6-Wire
JM601, 801	4242-041402	Jumper Lead, 4-Wire
LUG1, 2, 3	4211-4	Lug Terminal
<b>PCB-1 MAIN P.C. BOARD</b>		
<b>RESISTORS</b>		
R13	5102-4R74713	4.7 $\Omega$ , $\pm$ 2%, 1/4W, Fuse
R111, 112, 117, 118	5174-822381	8.2k $\Omega$ , $\pm$ 1%, 1/4W, Metal
R113, 114, 537, 538, 577, 578	5174-133381	13k $\Omega$ , $\pm$ 1%, 1/4W, Metal
R256	5102-1504715	15 $\Omega$ , $\pm$ 2%, 1/4W, Fuse
R363, 364	5102-1014715	100 $\Omega$ , $\pm$ 2%, 1/4W, Fuse
R533, 534	5174-162381	1.6k $\Omega$ , $\pm$ 1%, 1/4W, Metal
R543, 544	5174-512381	5.1k $\Omega$ , $\pm$ 1%, 1/4W, Metal
R597, 598	5174-112381	1.1k $\Omega$ , $\pm$ 1%, 1/4W, Metal
<b>CONTROLS</b>		
VR101, 102, 251	5101-20371920	20k $\Omega$ B
VR151, 152	5113-2037582	20k $\Omega$ A, Input Level
VR201, 202	5101-20271920	2k $\Omega$ B
VR203, 204, 205, 206, 207, 208, 209, 210, 252, 253, 503, 504	5101-10371920	10k $\Omega$ B
VR254	5113-1027921	1k $\Omega$ B, Bias Fine Trim
VR351, 352	5113-50279122	5k $\Omega$ A, Output Level
VR501, 502, 505, 506	5101-2027187	2k $\Omega$ B
<b>CAPACITORS</b>		
C4, 5	5345-228D041	2200 $\mu$ F, $\pm$ 20%, 25V, Electrolytic
C6, 7, 361, 563, 564	5345-226C041	22 $\mu$ F, $\pm$ 20%, 16V, Electrolytic
C8, 9	5345-108C041	1000 $\mu$ F, $\pm$ 20%, 16V, Electrolytic
C10	5345-476B041	47 $\mu$ F, $\pm$ 20%, 10V, Electrolytic
C11	5345-227B041	220 $\mu$ F, $\pm$ 20%, 10V, Electrolytic
C51	5345-L226M50	22 $\mu$ F, $\pm$ 20%, 50V, Electrolytic
C52	5345-L106M25	10 $\mu$ F, $\pm$ 20%, 25V, Electrolytic
C53	5345-337D041	330 $\mu$ F, $\pm$ 20%, 25V, Electrolytic
C103, 104, 111, 112, 529, 530, 555, 556	5345-106C0951	10 $\mu$ F, $\pm$ 20%, 16V, Electrolytic
C105, 106	5345-227A0951	220 $\mu$ F, $\pm$ 20%, 6.3V, Electrolytic
C107, 108, 109, 110	5359-332771	0.0033 $\mu$ F, $\pm$ 2%, 50V, Polypropylene
C113, 114	5345-227C041	220 $\mu$ F, $\pm$ 20%, 16V, Electrolytic
C151, 152	5345-L106M16	10 $\mu$ F, $\pm$ 20%, 16V, Electrolytic
C153, 154	5345-L476M10	47 $\mu$ F, $\pm$ 20%, 10V, Electrolytic
C157, 158, 301, 302, 505, 506, 539, 540, 561, 562	5345-106-16	10 $\mu$ F, +50% -10%, 16V, Electrolytic



Ref. No.	Part No.	Description
C159, 160	5345-476C041	47 $\mu$ F, $\pm$ 20%, 16V, Electrolytic
C207, 208	5345-224F0951	0.22 $\mu$ F, $\pm$ 20%, 50V, Electrolytic
C209, 210	5345-476B0951	47 $\mu$ F, $\pm$ 20%, 10V, Electrolytic
C215, 216	5345-225F0951	2.2 $\mu$ F, $\pm$ 20%, 50V, Electrolytic
C219, 220, 359, 360	5345-107C041	100 $\mu$ F, $\pm$ 20%, 16V, Electrolytic
C231, 232	5352-684571	0.68 $\mu$ F, $\pm$ 5%, 63V, Metal
C251	5345-476-16	47 $\mu$ F, +50% -10%, 16V, Electrolytic
C307, 308	5342-226C0951	22 $\mu$ F, $\pm$ 20%, 16V, Electrolytic
C351, 353, 354	5345-474-50	0.47 $\mu$ F, +75% -10%, 50V, Electrolytic
C352	5345-474F041	0.47 $\mu$ F, $\pm$ 20%, 50V, Electrolytic
C501, 502, 523, 524, 525, 526, 541, 542, 549, 550, 701	5345-105F0951	1 $\mu$ F, $\pm$ 20%, 50V, Electrolytic
C511, 512	5345-477C041	470 $\mu$ F, $\pm$ 20%, 16V, Electrolytic
C517, 518, 521, 522, 545, 546, 551, 552	5359-153771	0.015 $\mu$ F, $\pm$ 2%, 50V, Polypropylene
C569	5345-108B041	1000 $\mu$ F, $\pm$ 20%, 10V, Electrolytic
C601, 602	5345-477B041	470 $\mu$ F, $\pm$ 20%, 10V, Electrolytic
C703	5345-476-10	47 $\mu$ F, +50% -10%, 10V, Electrolytic
C705	5345-L334M50	0.33 $\mu$ F, $\pm$ 20%, 50V, Electrolytic
C813	5345-224F0212	0.22 $\mu$ F, $\pm$ 20%, 50V, Electrolytic
TC251, 252	5372-61	Trimmer Capacitor
<b>INTEGRATED CIRCUITS</b>		
IC201	5652- $\mu$ PC4558C	$\mu$ PC4558C
IC351	5652-NJM4556	NJM4556
IC501, 502	5652-HA11226	HA11226
<b>TRANSISTORS</b>		
Q1	5612-855(C)	2SB855(C)
Q2, 109, 110, 309, 310, 505, 506, 507, 508, 509, 510, 511, 512, 513, 514, 515, 516, 517, 518, 519, 520, 521, 522	5613-2603(F)or(E)	2SC2603(F) or 2SC2603(E)
Q3, 523, 524	5611-1115(F)or(E)	2SA1115(F) or 2SA1115(E)
Q4	5613-1419(C)	2SC1419(C)
Q5	5614-667(C)or(D)	2SD667(C) or 2SD667(D)
Q51, 707, 714, 721, 810	5611-1115(F)	2SA1115(F)
Q101, 102	5611-1190(E)or(D)	2SA1190(E) or 2SA1190(D)
Q103, 104	5613-2855(E)or(D)	2SC2855(E) or 2SC2855(D)
Q105, 106, 151, 152, 501, 502, 503, 504	5613-2320L(F)	2SC2320L(F)
Q107, 108	5611-999(F)	2SA999(F)
Q153, 154	5611-999L(F)	2SA999L(F)
Q251, 713	5614-667(C)	2SD667(C)
Q301, 302	5616-170(GR)	F.E.T., 2SK170(GR)
Q303, 304	5615-74(GR)	F.E.T., 2SJ74(GR)
Q305, 306	5611-984(F)	2SA984(F)
Q307, 308	5613-2274(F)	2SC2274(F)
Q351	5613-2320(F)or(E)	2SC2320(F) or 2SC2320(E)
Q701, 702, 703, 704	5613-1845(E)	2SC1845(E)
Q705, 706, 708, 709, 710, 711, 715, 716, 720, 722, 723, 809	5613-2603(F)	2SC2603(F)
Q712, 719	5612-647(C)	2SB647(C)
Q717, 718	5613-2878(B)	2SC2878(B)

Ref. No.	Part No.	Description
	<b>DIODES</b>	
D1	5685-1F	Bridge Silicon, SIRBA10
D2, 6, 51, 52, 53, 54, 55, 251, 503, 504, 505, 506, 507, 508, 509, 510, 511, 512, 513, 514, 517, 518, 701, 704, 705, 706, 818	5631-1S2473	1S2473
D3, 4	5635-RD9R1EB2	Zener, RD9.1EB2
D5	5635-RD6R2EB2	Zener, RD6.2EB2
D101, 102	5641-MV11	Varistor, MV11
D252	5635-RD3R9EB2	Zener, RD3.9EB2
D501, 502, 515, 516, 519, 520	5631-1K34A	1K34A
	<b>COILS</b>	
L201, 202	5933-70316	3.9mH
L203, 204	5932-70118	
L205, 206	5932-70115	
L301, 302, 501, 502	5995-363156	36mH
	<b>MISCELLANEOUS</b>	
F501, 502	5214-28	LC Components
OS101	6171-0701	Complex, Osc.
SW151	4431-A027110	Push Switch, Input Selector
SW251, 252, 253, 254	4431-04167163	Push Switch, Tape Selector
SW551	4421-082714	Slide Switch, Record/Playback
J151, 152	4452-0110	2-Pin Jack, Microphones
J351	4451-00107	Jack, Headphones
P701	4443-090177	Connector, 9-Pin
	<b>PCB-2 LOGIC CONTROL P.C. BOARD</b>	
	<b>CAPACITORS</b>	
C804	5342-106C0951	10 $\mu$ F, $\pm$ 20%, 16V, Electrolytic
C805	5345-474F0951	0.47 $\mu$ F, $\pm$ 20%, 50V, Electrolytic
C806	5345-106-16	10 $\mu$ F, +50% -10%, 16V, Electrolytic
C807	5352-824571	0.82 $\mu$ F, $\pm$ 5%, 63V, Metal
C809	5345-106C041	10 $\mu$ F, $\pm$ 20%, 16V, Electrolytic
C810, 811	5345-685D0212	6.8 $\mu$ F, $\pm$ 20%, 25V, Electrolytic
	<b>INTEGRATED CIRCUITS</b>	
IC801	5654-M54886P	M54886P
IC802	5654-AN6250	AN6250
	<b>TRANSISTORS</b>	
Q801, 805	5611-1115(F)	2SA1115(F)
Q802, 803, 804	5612-561(C)	2SB561(C)
Q806, 807, 808	5613-2603(F)	2SC2603(F)
	<b>DIODES</b>	
D801, 802, 808	5641-MV11	Varistor, MV11
D803, 804	5631-1K34A	1K34A
D805, 806, 807, 811	5632-DS135E	DS135E
D809, 810	5631-1S2473	1S2473
	<b>MISCELLANEOUS</b>	
SW801	4431-01020194	Push Switch, Memory
SW802, 803, 804, 805, 806, 807	4431-A017111	Push Switch, Stop, Play, Rew., F.FWD, Rec., Pause
SW808, 809	4431-02048059	Push Switch, Rec. Mute, Auto Repeat

Ref. No.	Part No.	Description
<b>PCB-3 METER AMP. P.C. BOARD</b>		
	<b>RESISTOR</b>	
R417	5102-4R74715	4.7Ω, ±2%, 1/4W, Fuse
	<b>CONTROLS</b>	
VR401, 402	5101-10471920	100kΩB
	<b>CAPACITORS</b>	
C401, 402	5345-105-50	1μF, +75% -10%, 50V, Electrolytic
C403, 404	5345-475-50	4.7μF, +75% -10%, 50V, Electrolytic
C405, 406	5345-L475M25	4.7μF, ±20%, 25V, Electrolytic
C407, 408	5345-L106M16	10μF, ±20%, 16V, Electrolytic
C409	5345-226-16	22μF, +50% -10%, 16V, Electrolytic
	<b>TRANSISTORS</b>	
Q401, 402, 404	5613-2603(F)or(E)	2SC2603(F) or 2SC2603(E)
Q403	5614-667(C)	2SD667(C)
	<b>DIODES</b>	
D401, 402, 403, 404	5631-1K34A	1K34A
	<b>MISCELLANEOUS</b>	
SW401	4431-01020194	Push Switch, Meter Ballistics
<b>PCB-4 DOLBY NR SWITCH P.C. BOARD</b>		
	<b>CAPACITORS</b>	
C567, 568	5345-226C041	22μF, ±20%, 16V, Electrolytic
	<b>TRANSISTORS</b>	
Q525, 526	5613-2603(F)or(E)	2SC2603(F) or 2SC2603(E)
	<b>MISCELLANEOUS</b>	
SW501, 502, 503	4431-03068050	Push Switch, Dolby NR, NR Type Selector, MPX Filter
<b>PCB-5 REC., PLAY AND PAUSE INDICATORS P.C. BOARD</b>		
D812	5637-TLR226	L.E.D., TLR226, Red, Rec.
D813	5637-TLY226	L.E.D., TLY226, Yellow, Pause
D814	5637-TLG226	L.E.D., TLG226, Green, Play
<b>PCB-6 AUTO REPEAT INDICATORS P.C. BOARD</b>		
D815, 816, 817	5637-GL9PR6	L.E.D., GL9PR6, Red
<b>PCB-7 DOLBY NR INDICATOR P.C. BOARD</b>		
D818	5637-GL9PG19	L.E.D., GL9PG19, Green, Dolby-B NR
D819	5637-GL9HY9	L.E.D., GL9HY9, Yellow, Dolby-C NR
<b>PCB-8 JACK P.C. BOARD</b>		
J1, 2, 3, 4	4484-31	4-Pin Jack, Line Input/Output
<b>PCB-9 POWER SWITCH P.C. BOARD</b>		
SW1	4431-A01016	Push Switch, Power
C1	5352-1030958	Capacitor, 0.01μF, ±20%, AC250V, Metalized Polyester
<b>PCB-10 POWER INDICATOR P.C. BOARD</b>		
D820	5637-GL9PR2	L.E.D., GL9PR2, Red
<b>PCB-11 REED SWITCH P.C. BOARD</b>		
SW810	4466-713	Reed Switch, Auto Stop
<b>PCB-12 FUSE P.C. BOARD</b>		
FU1, 2	5732-10202	Fuse, T1A, 250V
	4472-414	Fuse Holder (X4)

**PACKAGE**

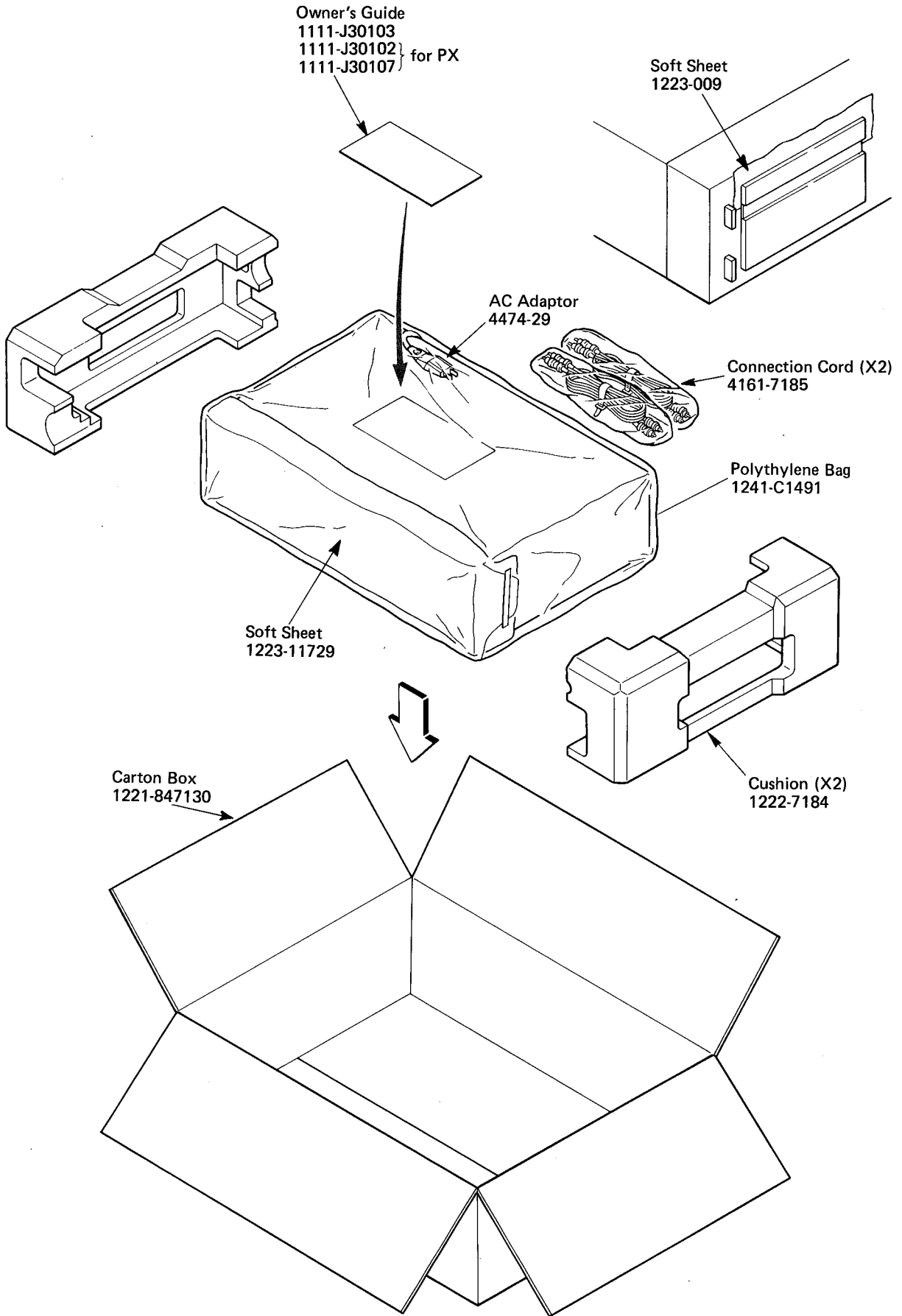

**SCHEMATIC DIAGRAM**

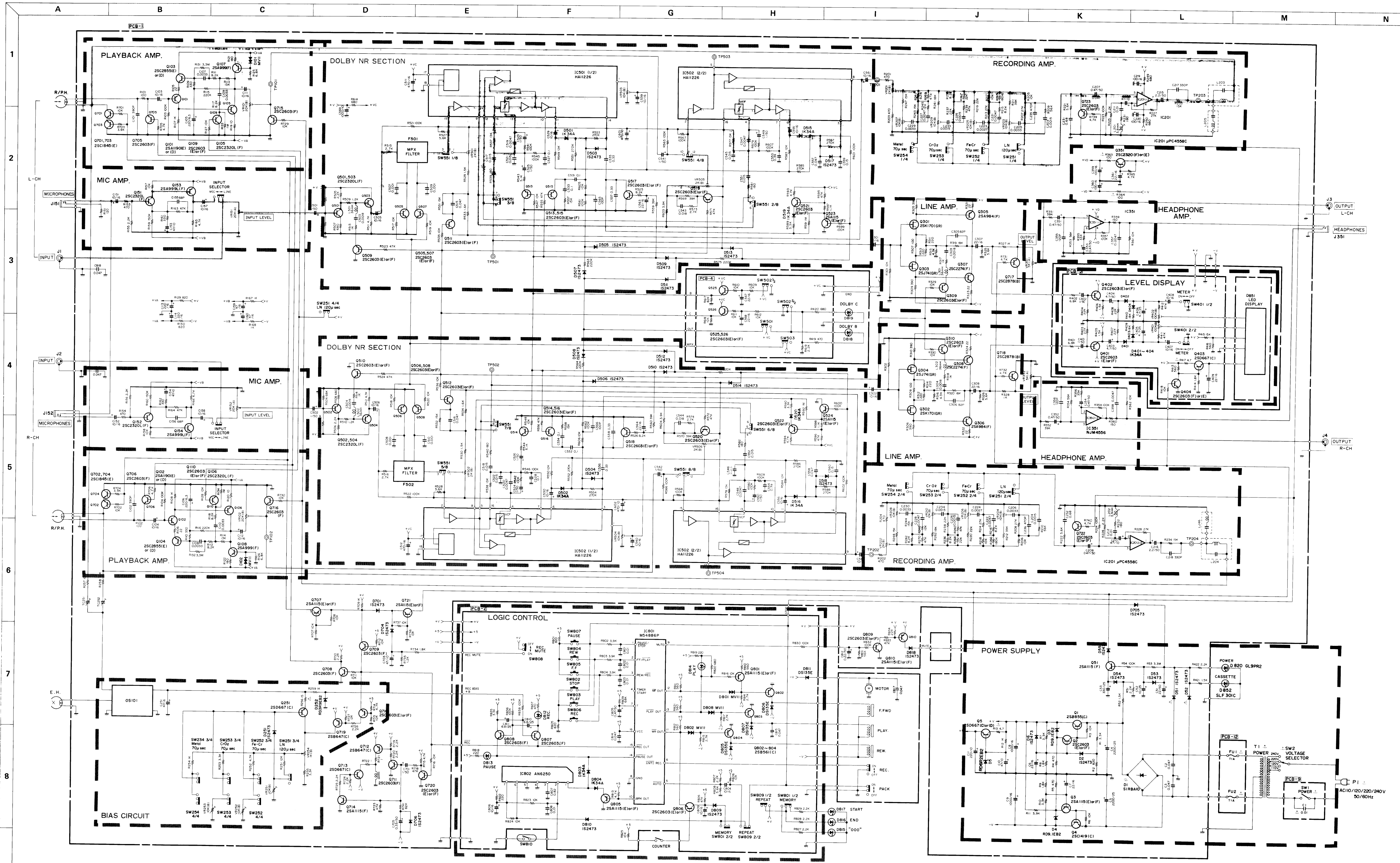

**PIN CONNECTION DIAGRAM OF TRANSISTORS, DIODES AND ICs.**

  S1RBA-D1	  MV11: D101, 102, 801, 802, 808	  DS135E: D805 ~ 807, 811	  1S2473: D2, 0.51 ~ 0.5, 251, 503 ~ 514, 701, 704 ~ 706, 809, 810, 818	  IN34A: D401 ~ 404, 501, 502, 515, 516, 519, 520, 803, 804	  25A1190: Q101, 102, 25C2855: Q103, 104, 25C2320: Q105, 106, 25C2274: Q307, 308, 25C1880: Q701 ~ 704, 25C2878: Q717, 718, 25B561: 802 ~ 804	     25K170: Q301, 302, 25J74: Q303, 304 GL9PR6: D815, 816, 817 GL9PG19: D818, GL9HY9: D819 GL9PR2: D820 SLF301C: D852
------------------	--	---------------------------------	---	---	--	---

- ALL RESISTANCE VALUES ARE IN Ω.
- KΩ = 1000Ω, MΩ = 1000KΩ
- THE WATTAGE OF RESISTOR IS 1/4W.
- ALL CAPACITANCE VALUES ARE IN μF UNLESS OTHERWISE NOTED. P = μF
- V: DC VOLTAGE AT NO SIGNAL; ... VOLT ... PLAYBACK MODE; (...) RECORD MODE
- SAFETY REQUIREMENTS COMPONENTS IN ACCORDANCE WITH PRESENT SAFETY REGULATIONS, THESE COMPONENTS MUST BE REPLACED BY ORIGINAL PARTS.

# SCHEMATIC DIAGRAM

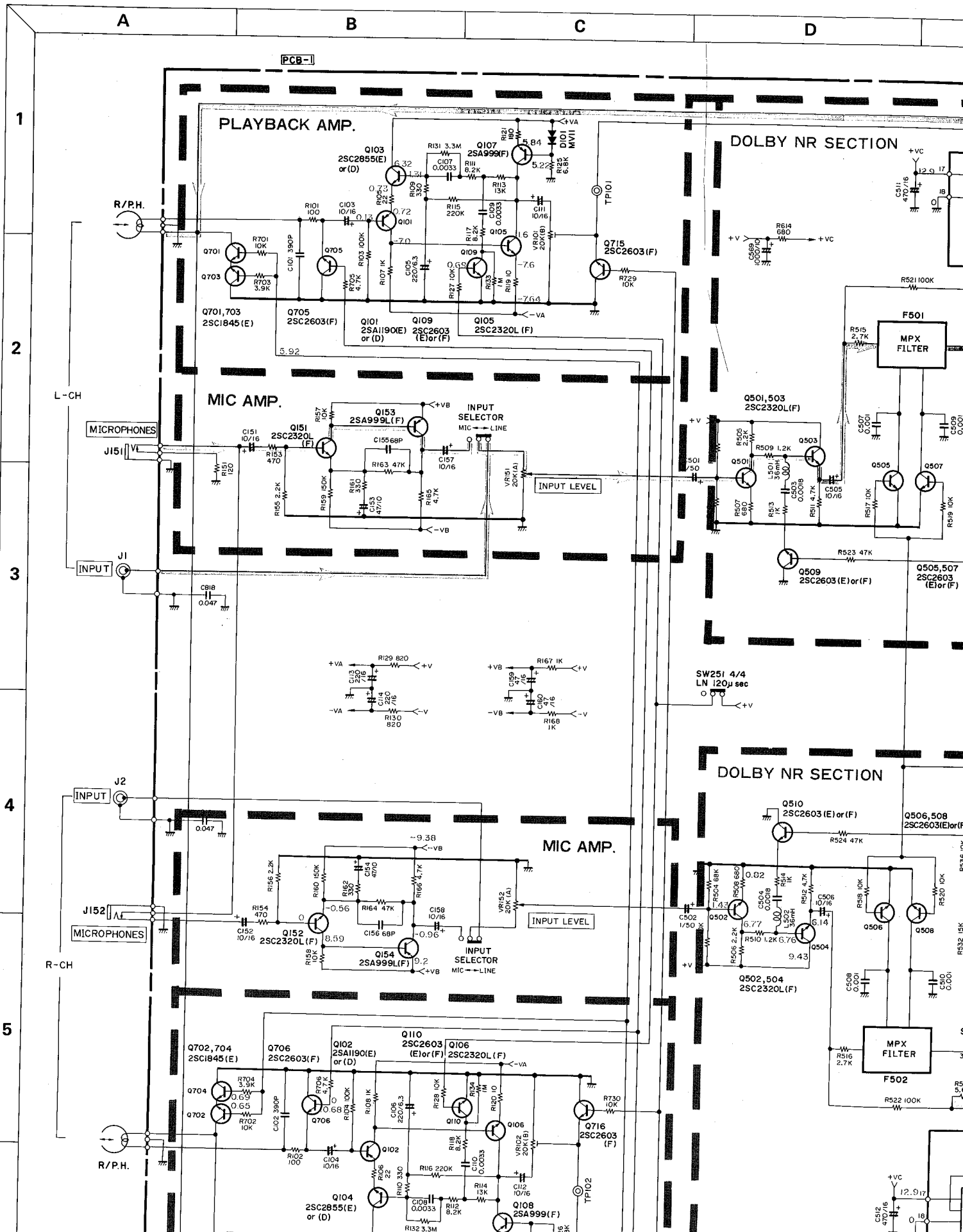

E

F

G

H

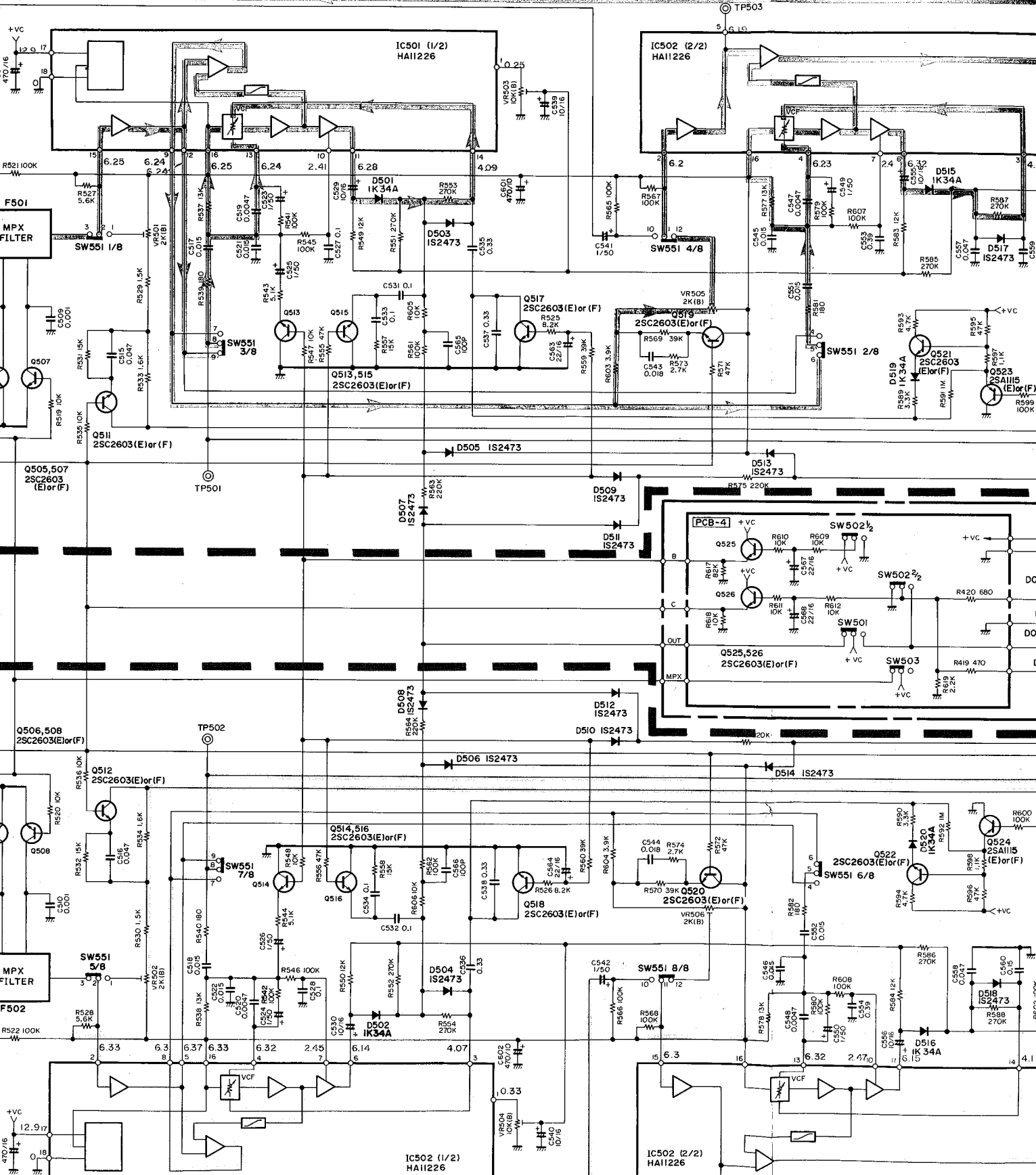

I

J

K

L

### RECORDING AMP.

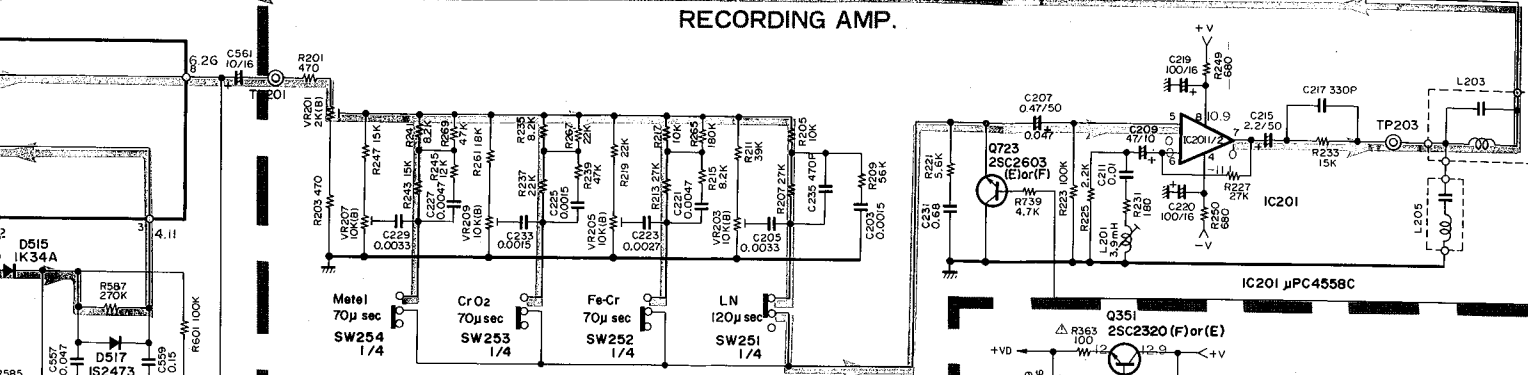

### LINE AMP.

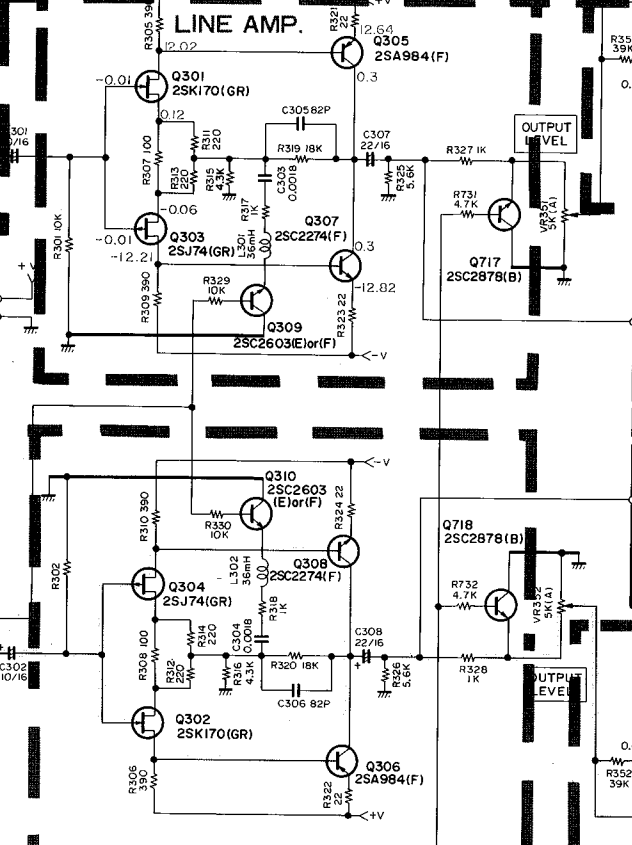

### HEADPHONE AMP.

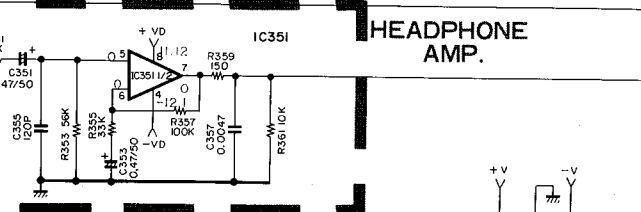

### LEVEL DISPLAY

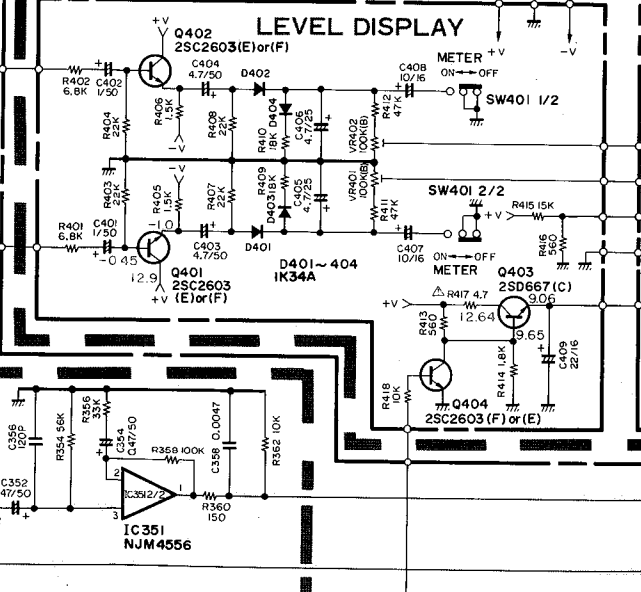

### LINE AMP.

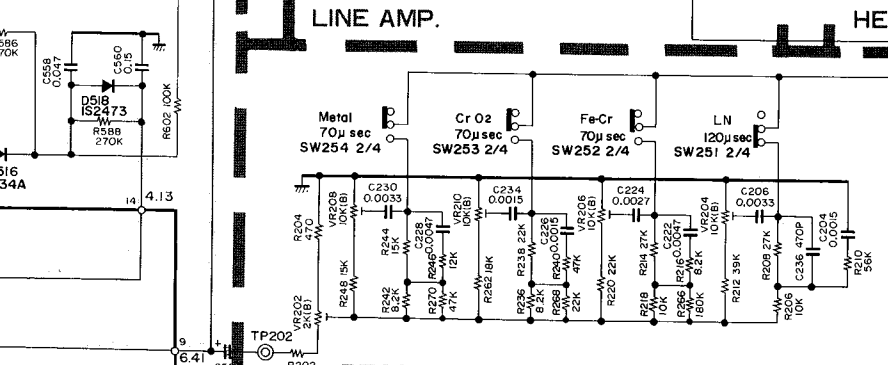

### HEADPHONE AMP.

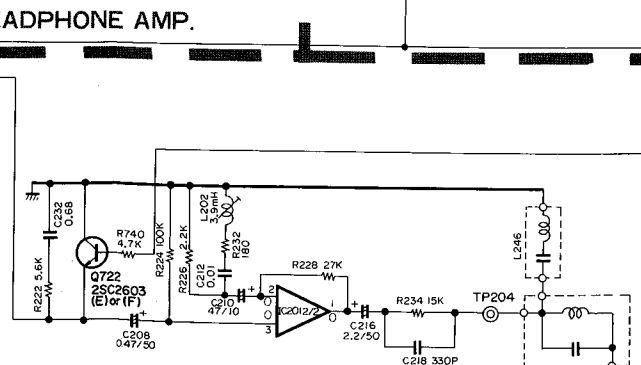



K

L

M

N

RECORDING AMP.

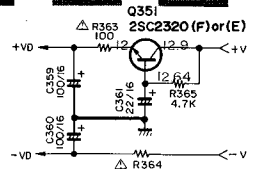
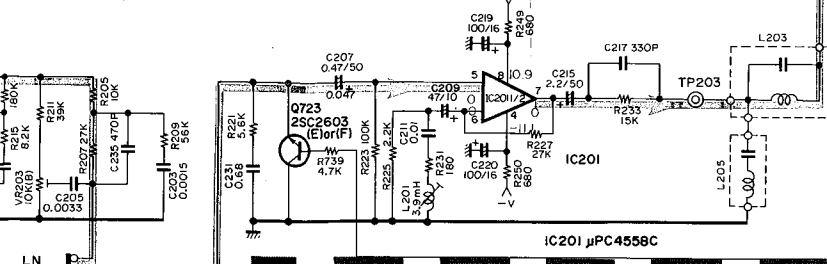

HEADPHONE AMP.

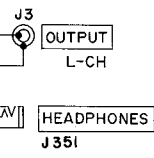
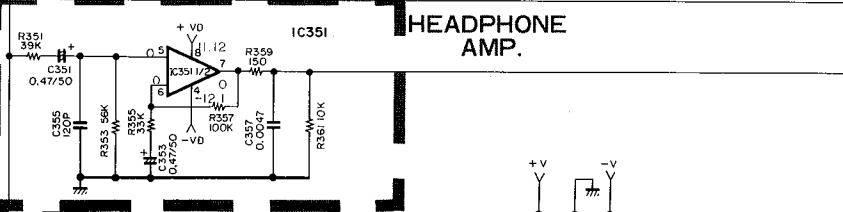

LEVEL DISPLAY

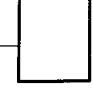
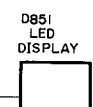
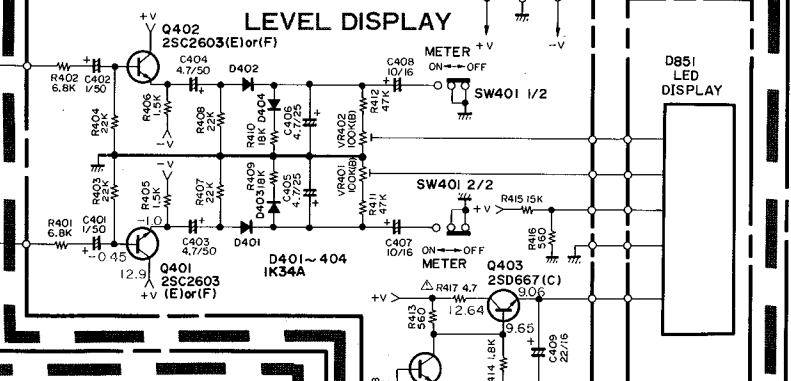

HEADPHONE AMP.

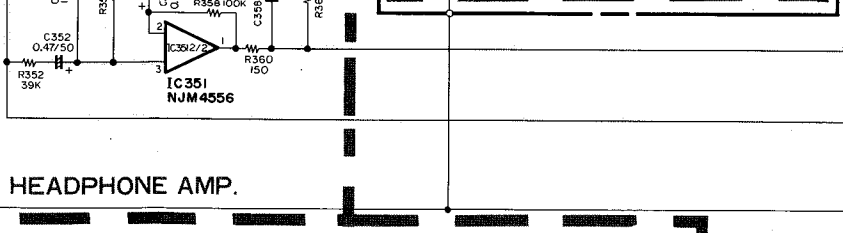

RECORDING AMP.

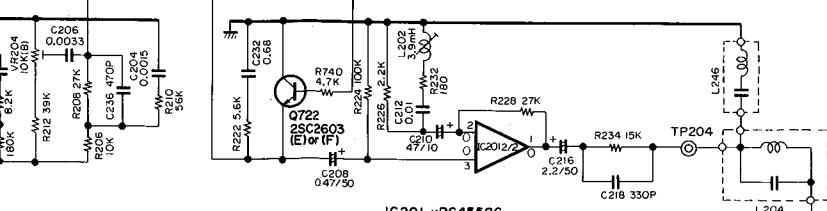

5  
6  
7  
8  
9

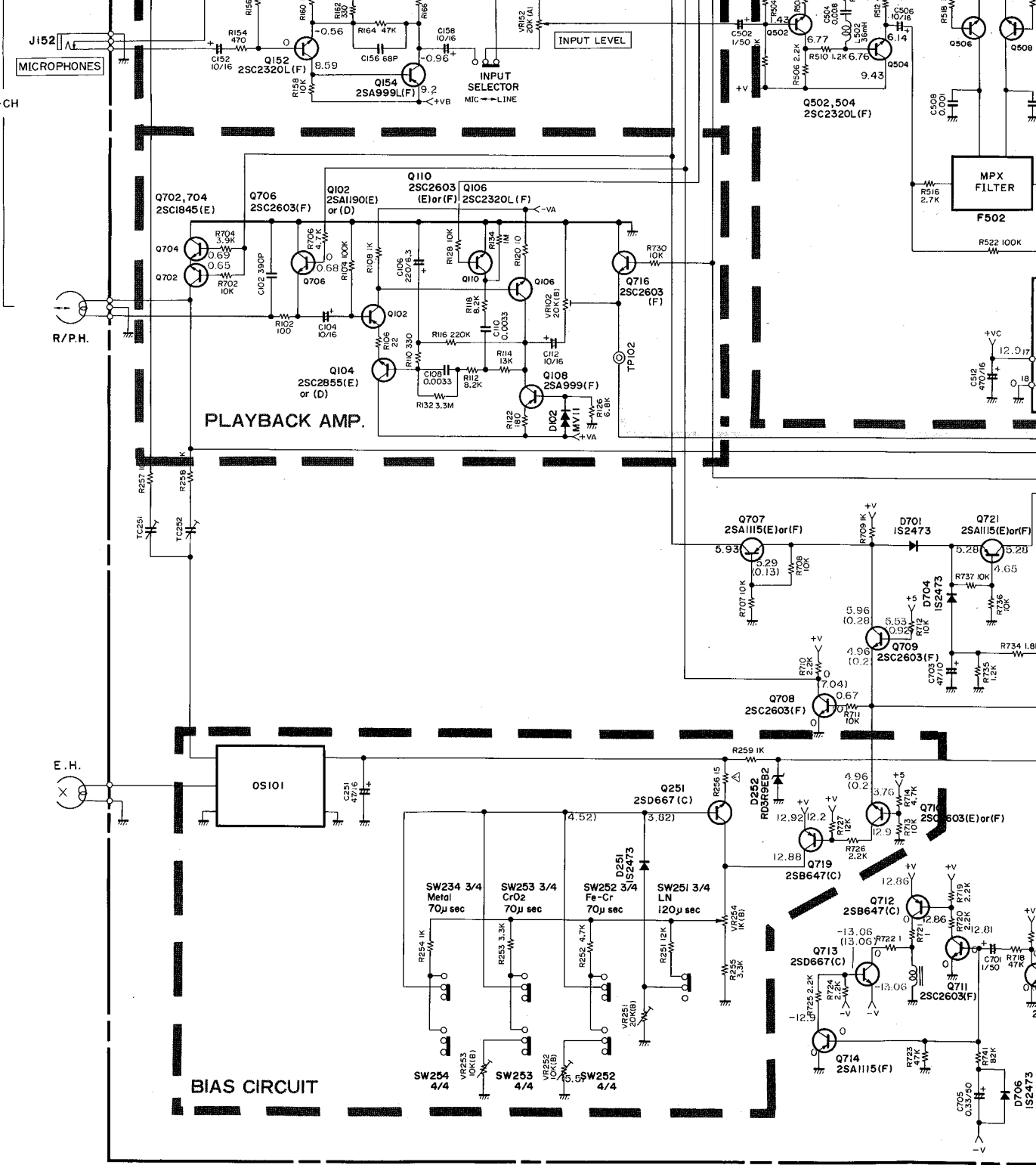

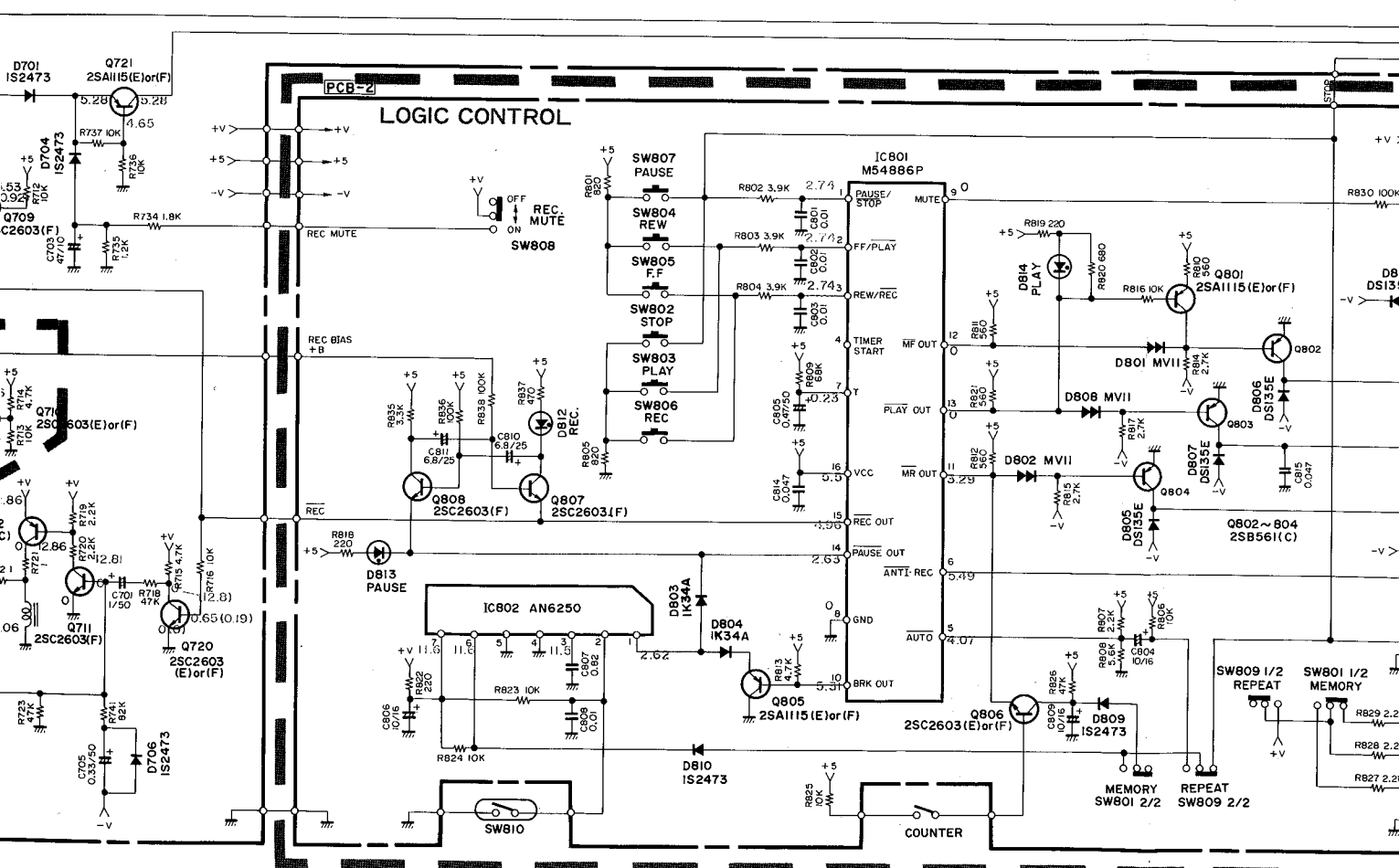
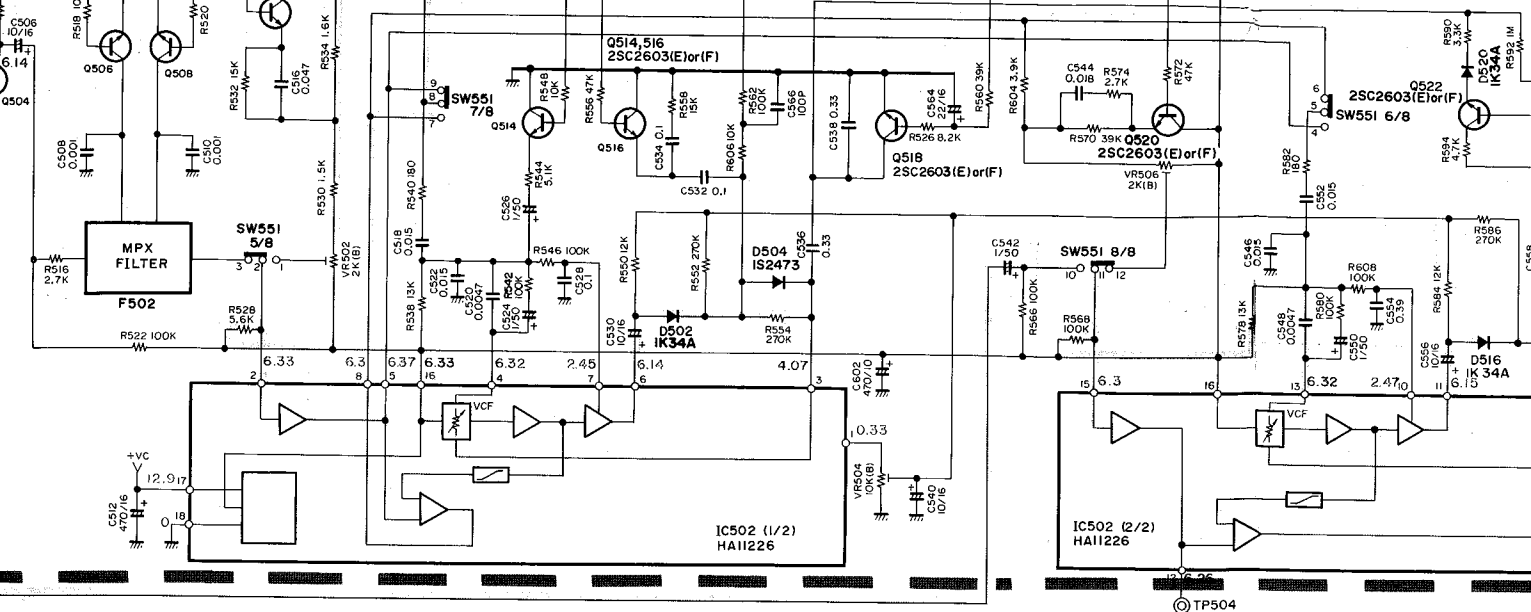

**PIN CONNECTION DIAGRAM OF TRANSISTORS, DIODES AND ICs.**

<p>μPC4558C: IC201 NJM4556: IC351</p>	<p>M54886P: IC801</p>	<p>HA11226: IC501, 502</p>	<p>AN6250: IC802</p>	<p>2SB855: Q1 2SC1419: Q4</p>	<p>2SD667: Q5, 251, 403, 713 2SB647: Q712, 719</p>	<p>2SC2603: Q2, 1, 402, 705, 722, Q3, Q4, 706, 721</p>
<p>S1RBA:D1</p>	<p>MV11: D101, 102, 801, 802, 808</p>	<p>DS135E: D805 ~ 807, 811</p>	<p>1S2473: D2, 6, 51 ~ 55, 251, 503 ~ 514, 701, 704 ~ 706, 809, 810, 818</p> <p>RD9.1EB2: D3, 4 RD6.2: D5 RD3.9EB2: D252</p>	<p>IN34A: D401 ~ 404, 501, 502, 515, 516, 519, 520, 803, 804</p>	<p>GL9PR6: DB15, 816, 81</p>	

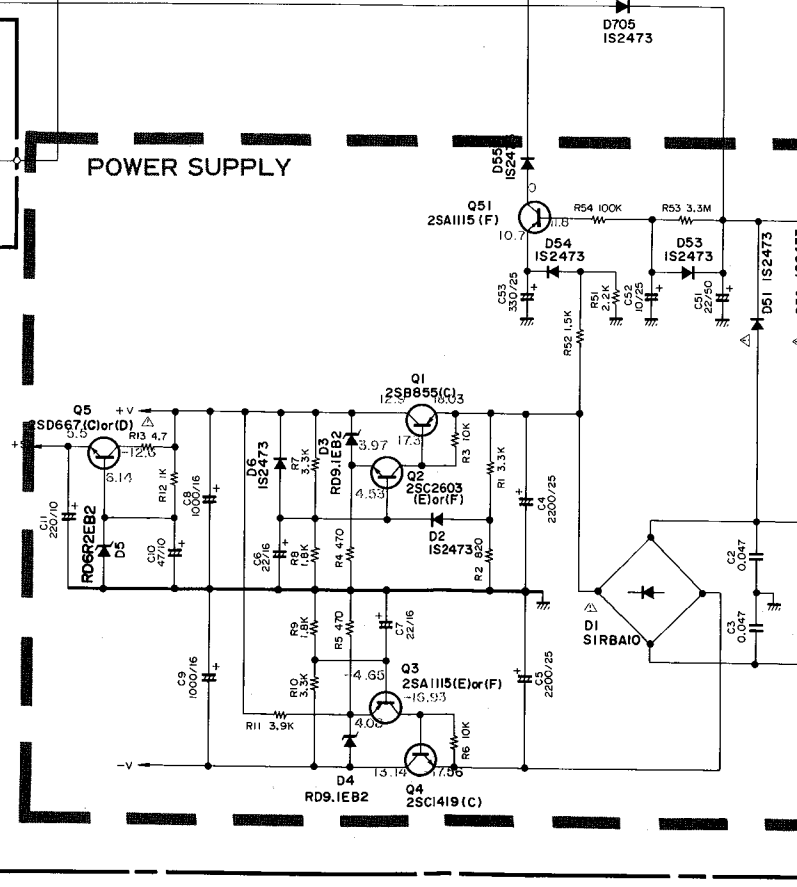
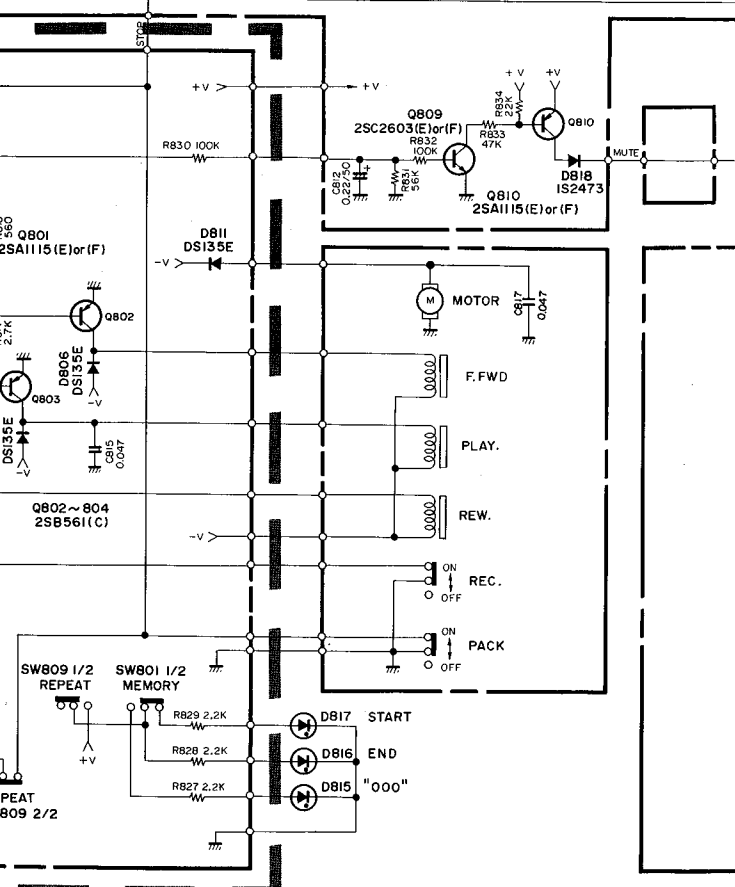
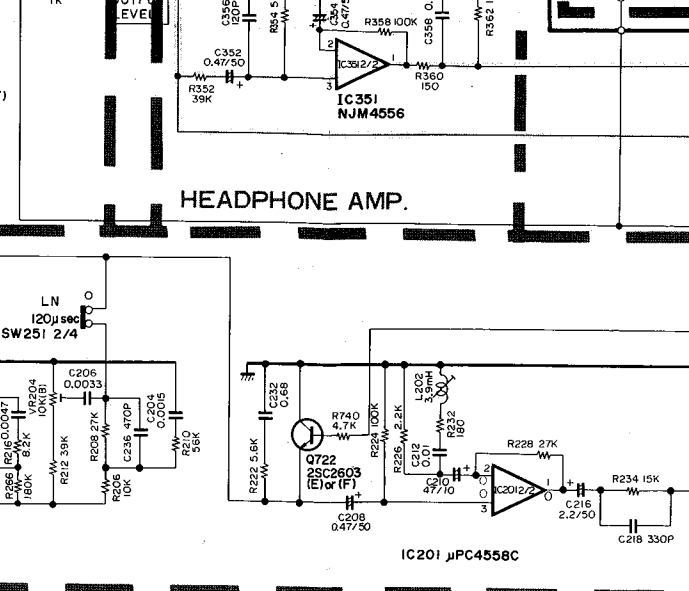
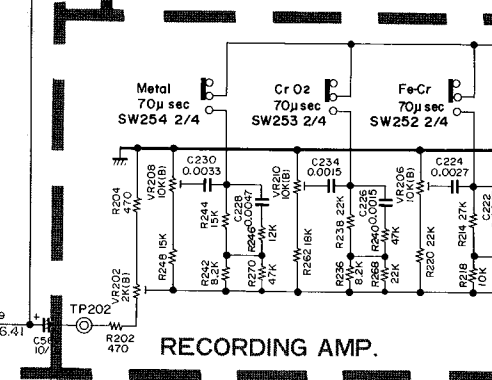
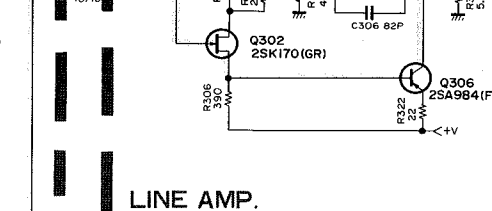
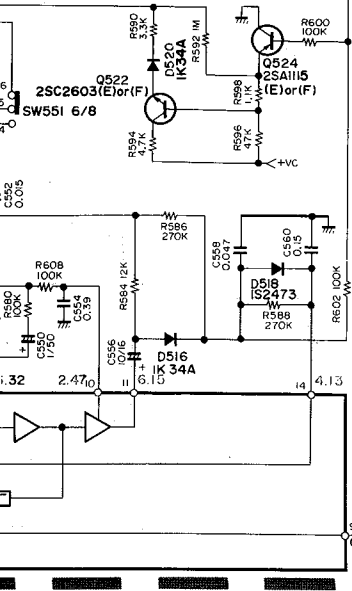

<p>2SC2603: Q2, 109, 110, 309, 310, 351, 401, 402, 404, 505 ~ 522, 525, 526, 705, 706, 708 ~ 711, 715, 716, 720, 722, 723, 806 ~ 809</p> <p>2SA1115: Q3, 51, 523, 524, 704, 707, 714, 721, 801, 805, 810</p>	<p>2SA1190: Q101, 102</p> <p>2SC2855: Q103, 104</p> <p>2SC2320: Q105, 106, 151, 152, 501 ~ 504</p>	<p>2SA999: Q107, 108</p> <p>2SA999L: Q153, 154</p> <p>2SA984: Q305, 306</p> <p>2SC2274: Q307, 308</p> <p>2SC1890: Q701 ~ 704</p> <p>2SC2878: Q717, 718</p> <p>2SB561: Q802 ~ 804</p>	<p>2SK170: Q301, 302</p> <p>2SJ74: Q303, 304</p>
<p>GL9PR6: D815, 816, 817</p>	<p>GL9PG19: D818</p> <p>GL9HY9: D819</p>	<p>GL9PR2: D820</p>	<p>SLF301C: D852</p>

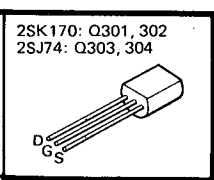
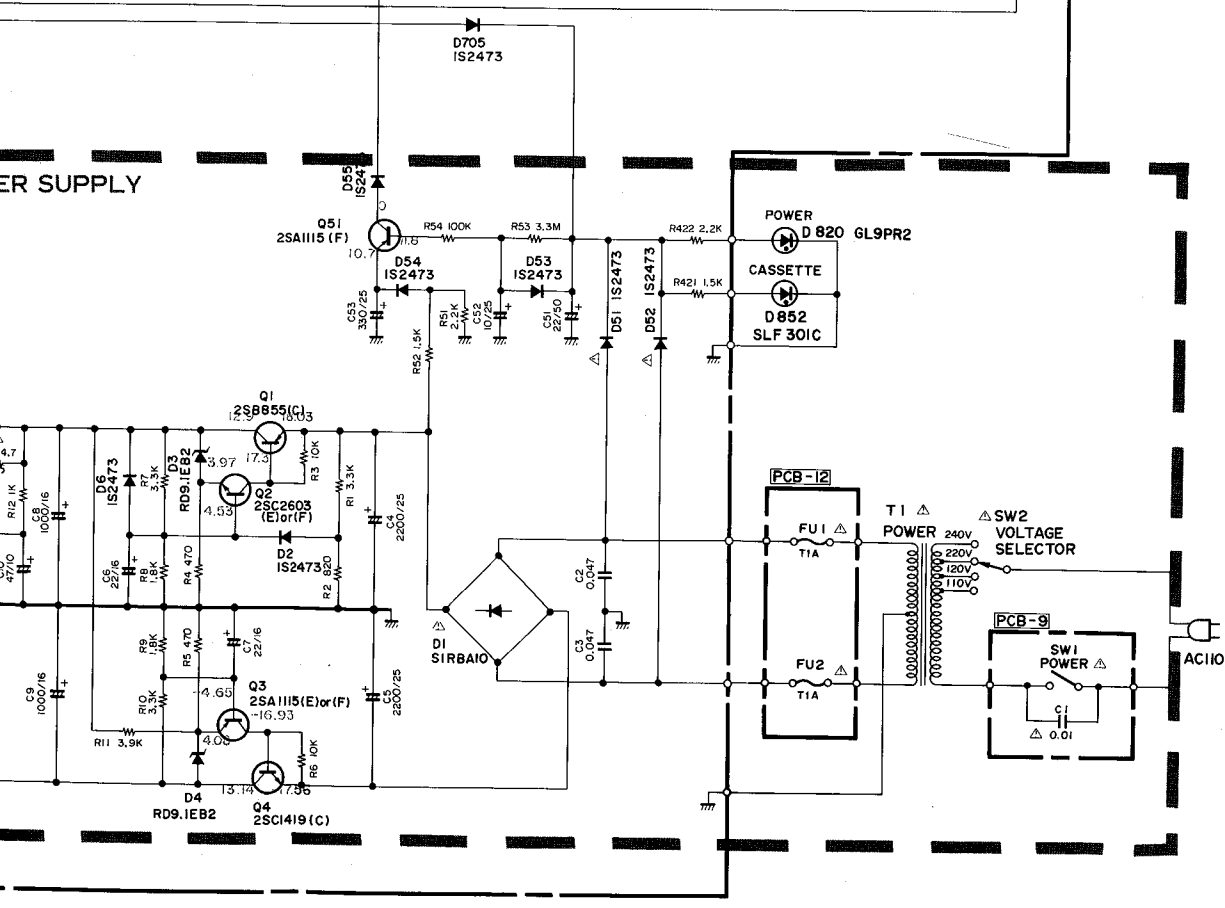
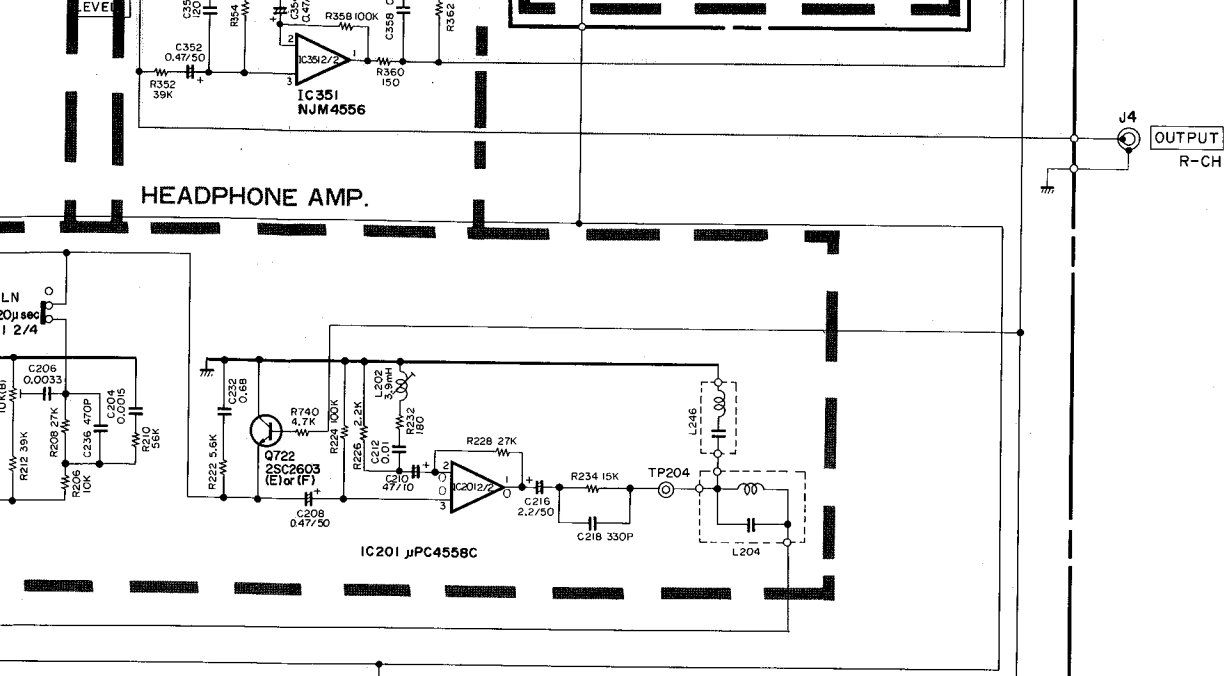

..... RECORDING SIGNAL (Lch)  
 ..... PLAYBACK SIGNAL (Rch)

1. ALL RESISTANCE VALUES ARE IN  $\Omega$ .  
 $K\Omega = 1000\Omega$ ,  $M\Omega = 1000K\Omega$
2. THE WATTAGE OF RESISTOR IS 1/4W.
3. ALL CAPACITANCE VALUES ARE IN  $\mu F$  UNLESS OTHERWISE NOTED.  $P = \mu\mu F$
4. V:DC VOLTAGE AT NO SIGNAL : ... VOLT  
 ... PLAYBACK MODE, (...) RECORD MODE
5.  $\Delta$  SAFETY-REQUIREMENTS COMPONENTS IN ACCORDANCE WITH PRESENT SAFETY REGULATIONS, THESE COMPONENTS MUST ONLY BE REPLACED BY ORIGINAL PARTS.



WIRING DIAGRAM

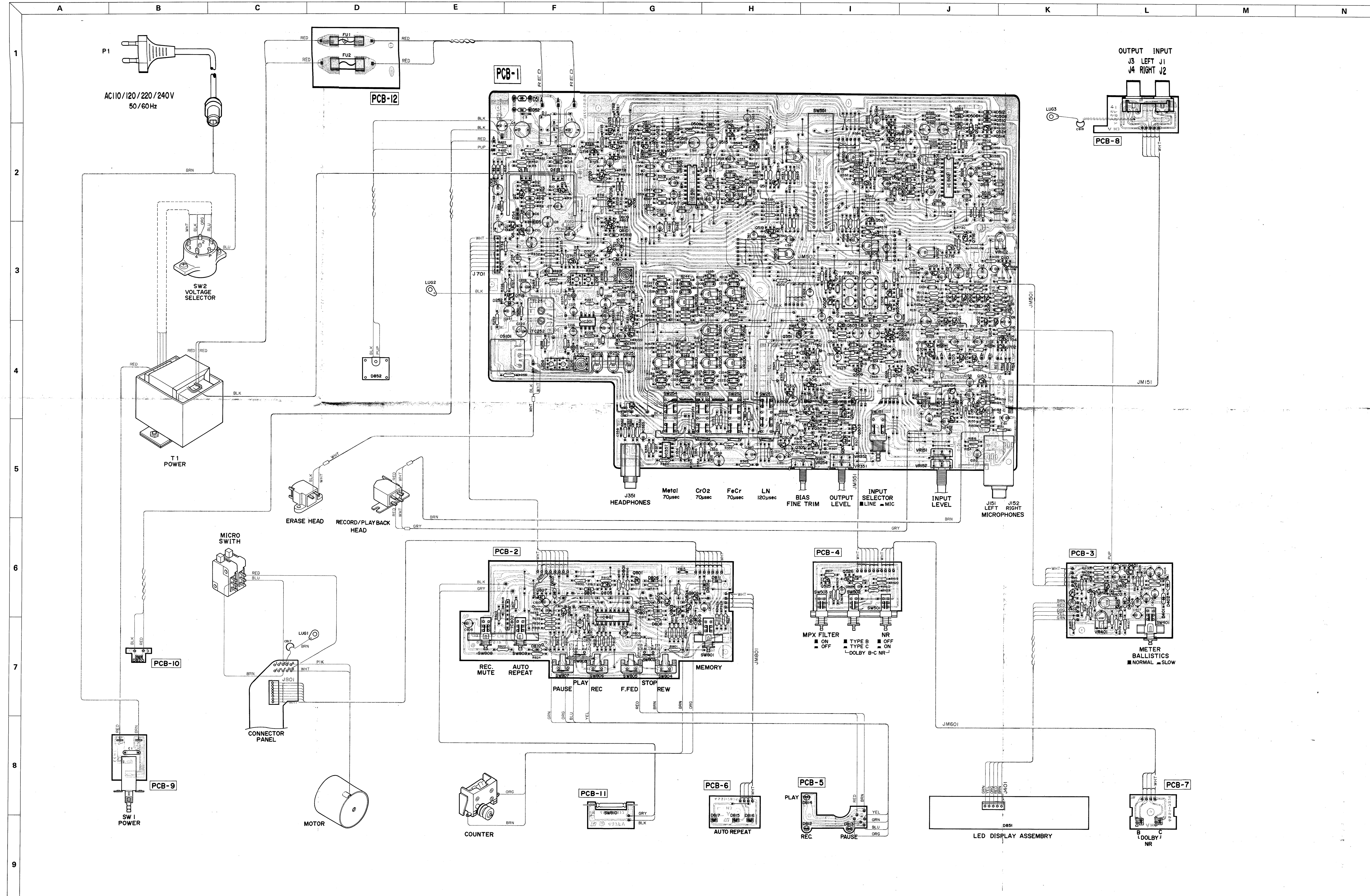

- WIRE COLOR ABBREVIATIONS
- RED : Red
- ORG : Orange
- BLU : Blue
- WHT : White
- GRN : Green
- BLK : Black
- YEL : Yellow
- PUP : Purple
- PIK : Pink

WIRING DIAGRAM

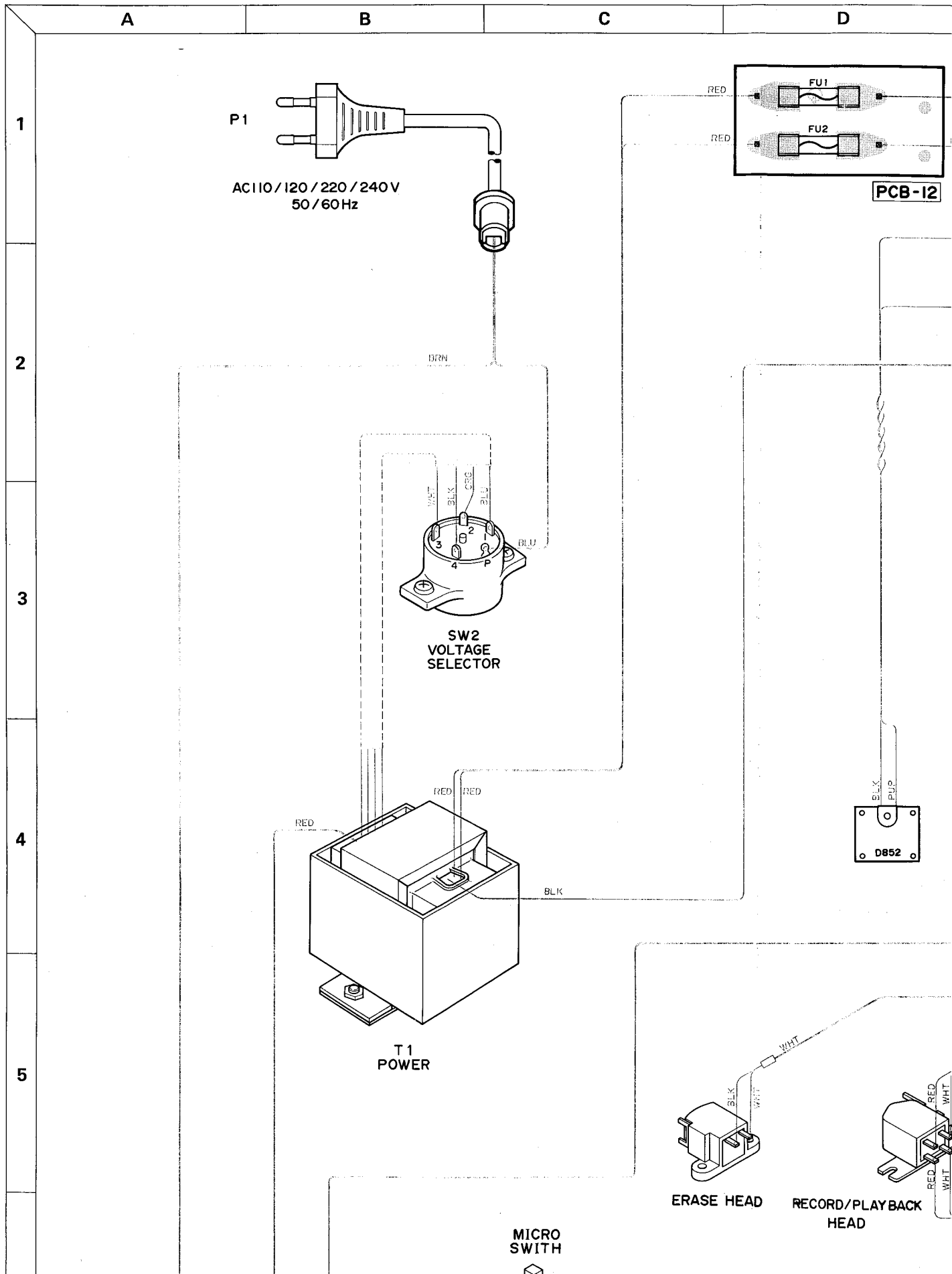

E

F

G

H

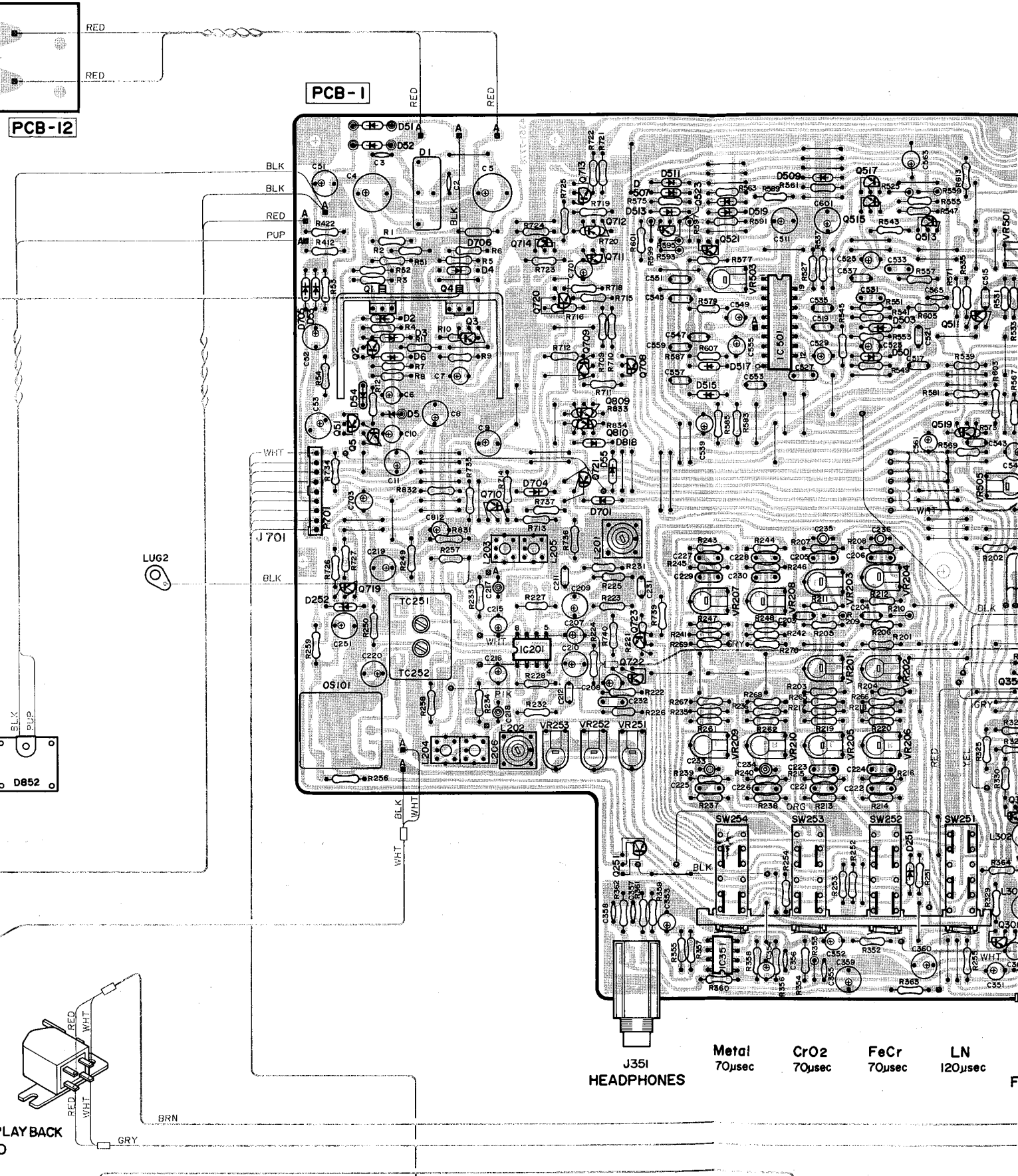

PCB-12

PCB-1

PCB-2

PLAYBACK

J351 HEADPHONES

Metal	CrO2	FeCr	LN
70µsec	70µsec	70µsec	120µsec

F



I

J

K

L

OUTPUT INPUT  
 J3 LEFT J1  
 J4 RIGHT J2

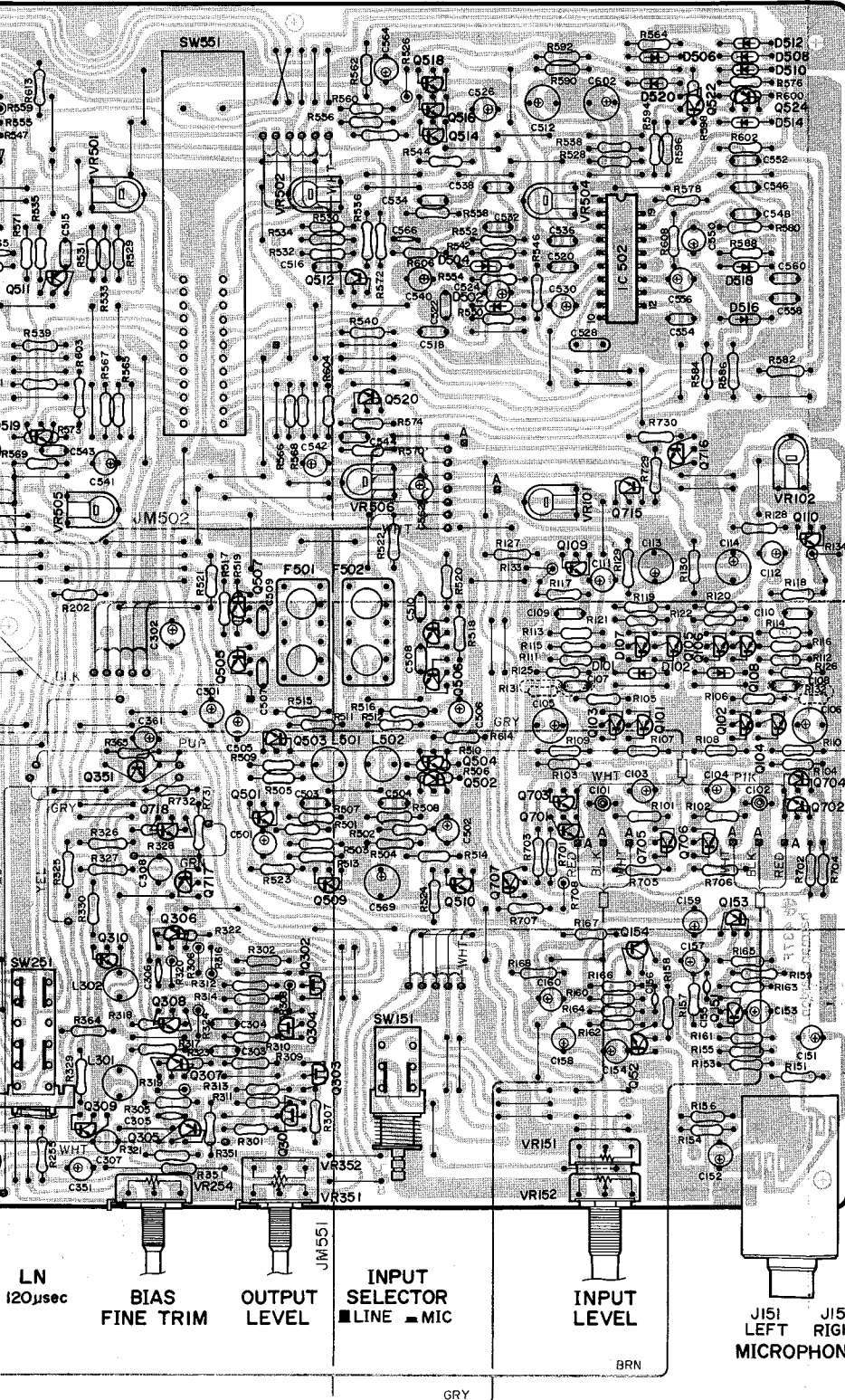

LUG3

CB16

PCB-8

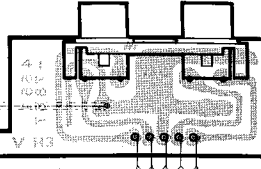

WHT

JM501

JM151

LN  
120µsec

BIAS  
FINE TRIM

OUTPUT  
LEVEL

INPUT  
SELECTOR  
■ LINE ■ MIC

INPUT  
LEVEL

J151 J152  
LEFT RIGHT  
MICROPHONES

BRN

GRY

PCB-4

PCB-3

UP

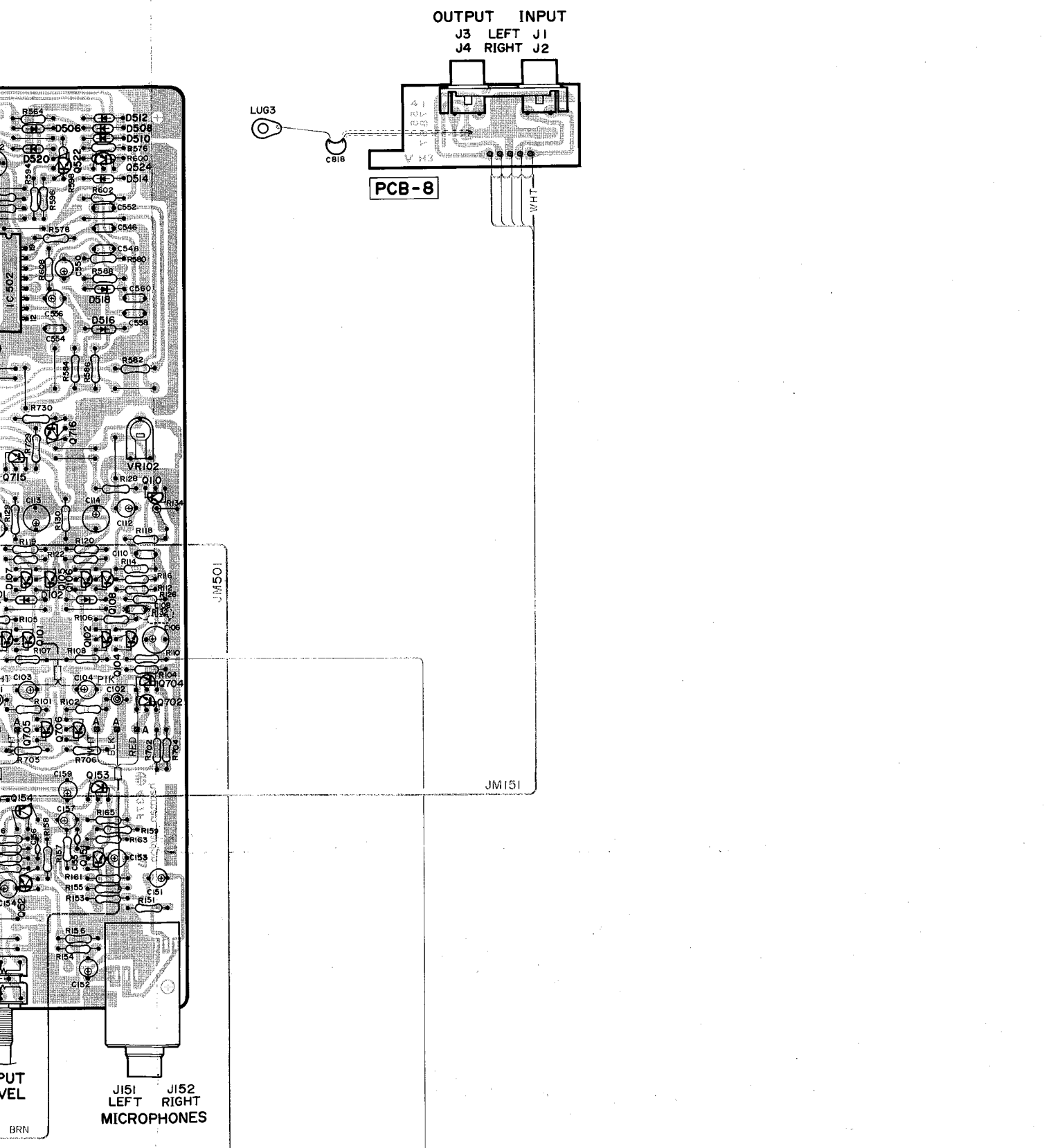

OUTPUT INPUT

J3 LEFT J1  
J4 RIGHT J2

PCB-8

LUG3

C818

WHT

JW501

JM151

PUT

VEL

BRN

J151 J152  
LEFT RIGHT  
MICROPHONES

PCB-3

UP

5

T1  
POWER

ERASE HEAD

RECORD/PLAYBACK  
HEAD

6

MICRO  
SWITH

7

PCB-10

CONNECTOR  
PANEL

8

PCB-9

SW I  
POWER

MOTOR

9

• WIRE COLOR ABBREVIATIONS

- RED : Red
- ORG : Orange
- BLU : Blue
- WHT : White
- GRN : Green
- BLK : Black
- YEL : Yellow
- PUP : Purple
- PIK : Pink

D/PLAYBACK  
HEAD

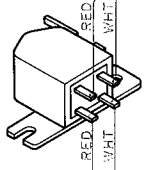

BRN

GRY

J351  
HEADPHONES

Metal  
70µsec

CrO2  
70µsec

FeCr  
70µsec

LN  
120µsec

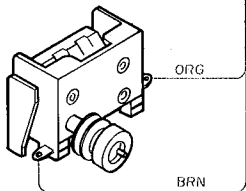
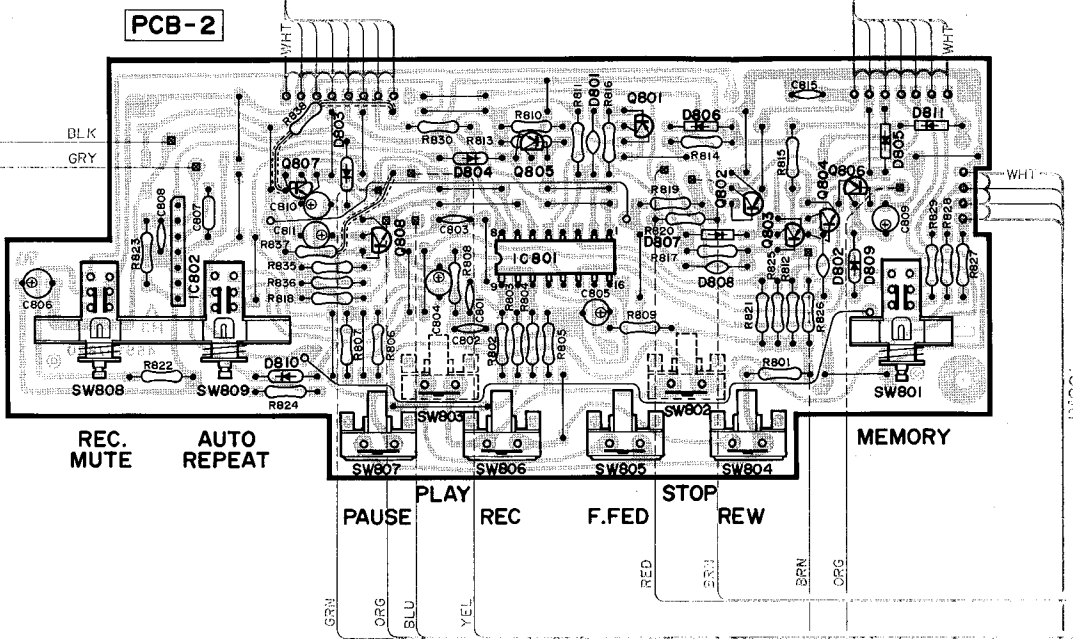

COUNTER

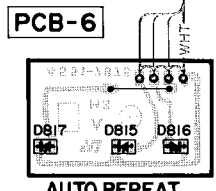
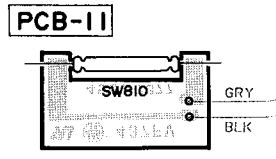

AUTO REPEAT

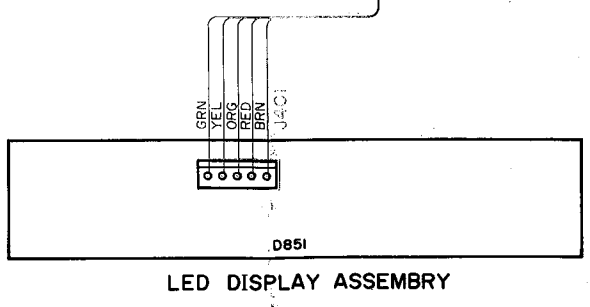
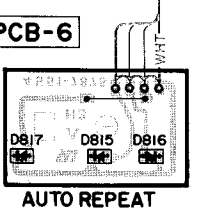
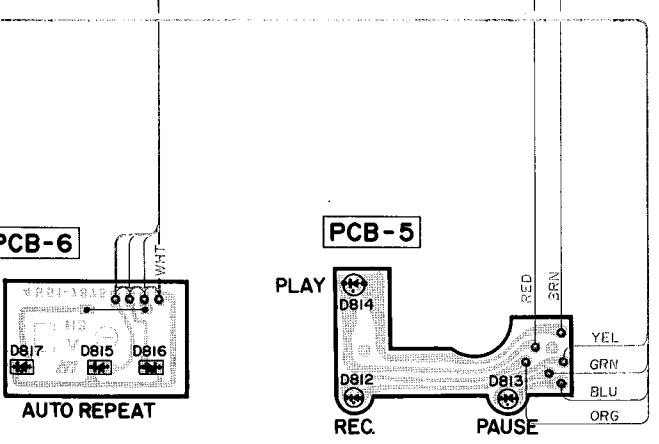
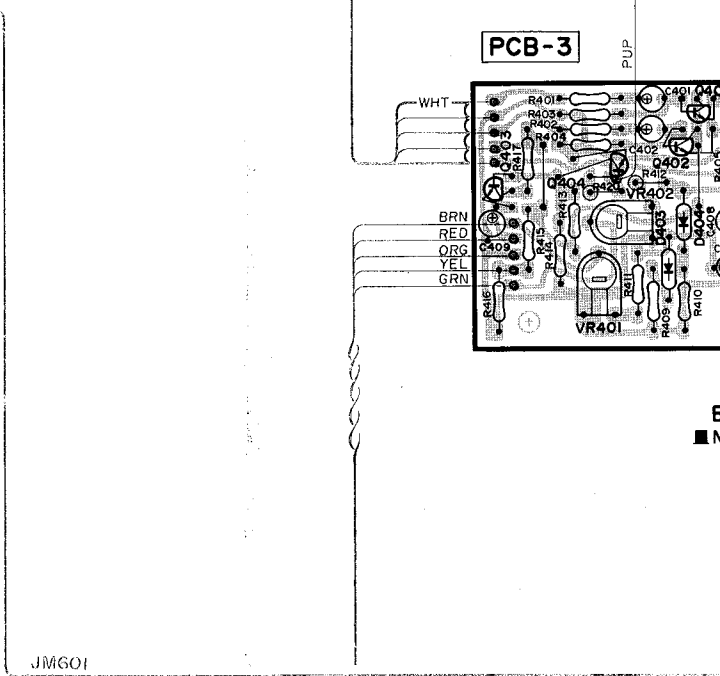
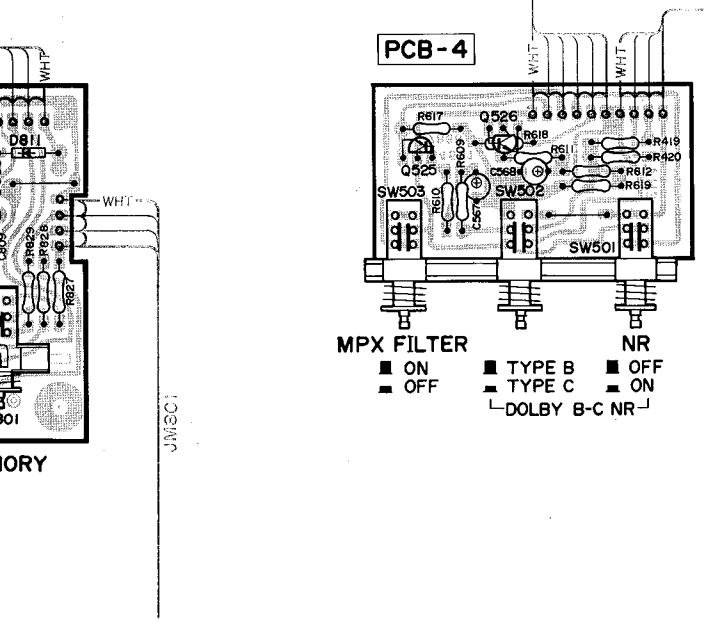
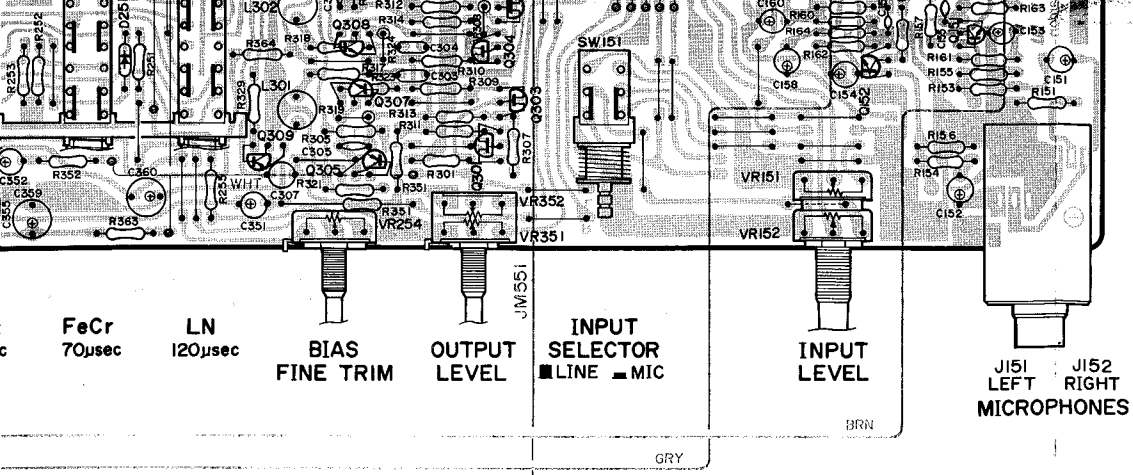

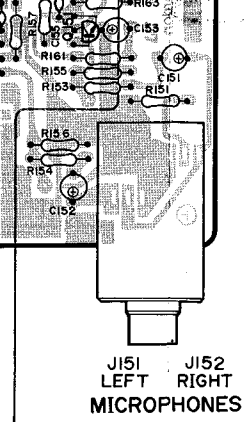

J151 J152  
LEFT RIGHT  
MICROPHONES

PCB-3

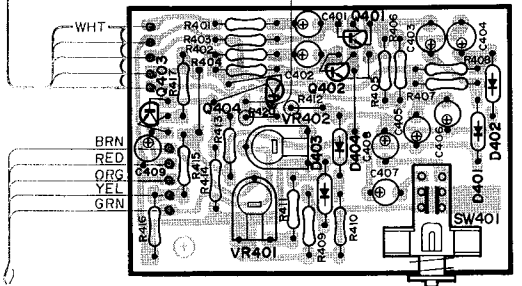

METER  
BALLISTICS  
■ NORMAL ■ SLOW

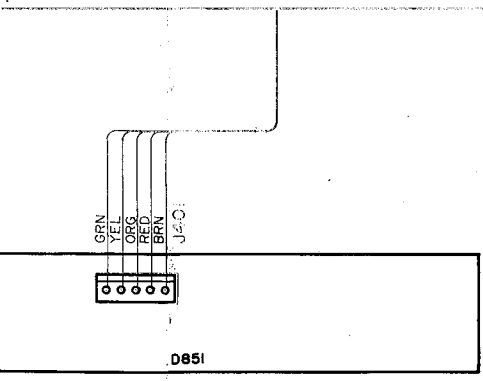

LED DISPLAY ASSEMBRY

PCB-7

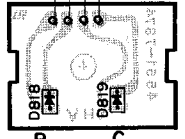

B C  
'DOLBY'  
NR